

INTERNATIONAL  
RECOMMENDATION

**OIML R 140**  
Edition 2007 (E)

---

Measuring systems for gaseous fuel

Systèmes de mesurage de gaz

---





## Contents

Foreword	.....	5
<b>1</b>	<b>Introduction.....</b>	<b>6</b>
<b>2</b>	<b>Scope of application.....</b>	<b>7</b>
<b>3</b>	<b>Terminology.....</b>	<b>8</b>
T.1	The measuring system and its constituents.....	8
T.2	Metrological characteristics.....	12
T.3	Tests and test conditions.....	15
T.4	Electronic or electrical equipment.....	16
<b>4</b>	<b>Description.....</b>	<b>17</b>
4.1	Components of a measuring system.....	17
4.2	Concept of a measuring system.....	18
4.3	Flow measurement.....	18
<b>5</b>	<b>Units of measurement and abbreviations.....</b>	<b>18</b>
5.1	Units of measurement.....	18
5.2	Abbreviations.....	18
<b>6</b>	<b>Metrological requirements.....</b>	<b>19</b>
6.1	Accuracy classes.....	19
6.2	Maximum permissible errors (mpes) for measuring systems.....	19
6.3	mpes for modules.....	20
6.4	Other metrological performances of a CVDD.....	24
6.5	mpes for calculators.....	26
6.6	Repeatability error of a metering module.....	26
6.7	Endurance of a metering module.....	26
6.8	Maximum permissible errors for in service instruments or subsequent verifications.....	26
<b>7</b>	<b>Technical requirements for measuring systems.....</b>	<b>27</b>
7.1	General.....	27
7.2	Metering module.....	29
7.3	Converting into volume at base conditions or mass.....	30
7.4	Determination of energy.....	33
7.5	Marking.....	37
7.6	Sealing.....	37
<b>8</b>	<b>Technical requirements for meters, metering modules and ancillary devices.....</b>	<b>38</b>
8.1	Meters and metering modules.....	38
8.2	Indicating device.....	39
8.3	Printing device.....	40
8.4	Memory device.....	41
8.5	Associated measuring instruments.....	41
8.6	Volume conversion device.....	42
8.7	Calculator.....	42
8.8	Calorific value determining device.....	42
8.9	Energy conversion device.....	44

<b>9</b>	<b>Technical requirements for electronic devices .....</b>	<b>44</b>
9.1	General requirements .....	44
9.2	Power supply device .....	44
9.3	Checking facilities .....	45
<b>10</b>	<b>Metrological control .....</b>	<b>49</b>
10.1	General .....	49
10.2	Type approval .....	49
10.3	Initial verification .....	58
10.4	Subsequent verifications .....	60
10.5	Documented provisions, quality assurance systems and routine controls .....	60
Annex A	Performance environmental influence tests for electronic measuring systems (Mandatory) .....	61
Annex B	Influence tests for type approval of metering modules (Mandatory) .....	74
Annex C	Principles of the modular approach and of error calculation (Mandatory/Informative).....	78
Annex D	General considerations on gas measuring systems (Informative) .....	88
Annex E	Calibration gases (Mandatory/informative).....	96
Annex F	Minimum test quantities for measuring systems and devices (Informative) .....	103
Annex G	Conversion of gas mass to volume at base conditions (Informative).....	105
Annex H	Bibliography (Informative) .....	110

## Foreword

The International Organization of Legal Metrology (OIML) is a worldwide, intergovernmental organization whose primary aim is to harmonize the regulations and metrological controls applied by the national metrological services, or related organizations, of its Member States. The main categories of OIML publications are:

- **International Recommendations (OIML R)**, which are model regulations that establish the metrological characteristics required of certain measuring instruments and which specify methods and equipment for checking their conformity. OIML Member States shall implement these Recommendations to the greatest possible extent;
- **International Documents (OIML D)**, which are informative in nature and which are intended to harmonize and improve work in the field of legal metrology;
- **International Guides (OIML G)**, which are also informative in nature and which are intended to give guidelines for the application of certain requirements to legal metrology; and
- **International Basic Publications (OIML B)**, which define the operating rules of the various OIML structures and systems.

OIML Draft Recommendations, Documents and Guides are developed by Technical Committees or Subcommittees which comprise representatives from the Member States. Certain international and regional institutions also participate on a consultation basis. Cooperative agreements have been established between the OIML and certain institutions, such as ISO and the IEC, with the objective of avoiding contradictory requirements. Consequently, manufacturers and users of measuring instruments, test laboratories, etc. may simultaneously apply OIML publications and those of other institutions.

International Recommendations, Documents, Guides and Basic Publications are published in English (E) and translated into French (F) and are subject to periodic revision.

Additionally, the OIML publishes or participates in the publication of **Vocabularies (OIML V)** and periodically commissions legal metrology experts to write **Expert Reports (OIML E)**. Expert Reports are intended to provide information and advice, and are written solely from the viewpoint of their author, without the involvement of a Technical Committee or Subcommittee, nor that of the CIML. Thus, they do not necessarily represent the views of the OIML.

This publication - reference OIML R 140, edition 2007 (E) - was developed by the OIML Technical Subcommittee TC 8/SC 7 *Gas metering*. Together with OIML R 137-1 *Gas meters Part 1: Requirements* (2006) it supersedes R 6 (1989). It was approved for final publication by the International Committee of Legal Metrology in 2007 and will be submitted to the International Conference of Legal Metrology in 2008 for formal sanction.

OIML Publications may be downloaded from the OIML web site in the form of PDF files. Additional information on OIML Publications may be obtained from the Organization's headquarters:

Bureau International de Métrologie Légale  
11, rue Turgot - 75009 Paris - France  
Telephone: 33 (0)1 48 78 12 82  
Fax: 33 (0)1 42 82 17 27  
E-mail: [biml@oiml.org](mailto:biml@oiml.org)  
Internet: [www.oiml.org](http://www.oiml.org)

# Measuring systems for gaseous fuel

## 1 Introduction

### 1.1 Preliminary information on the scope

Traditionally and until now, in many countries legal metrology was mainly concerned with gas meters in the field of gas metering. However, in general the price of the transaction for a quantity of gas not only depends on the volume measured using volume meters that are subject to metrological control, but also on the metering parameters (installation, gas meter, pressure, temperature) and the nature of the gas. For these reasons, this Recommendation introduces the notion of measuring system.

National authorities may decide whether the legal metrological control is applicable:

*1 Only to meters*

In this case it is sufficient to refer only to OIML R 137-1.

*2 Only to some individual parts of the measuring system*

In this case they should refer only to the corresponding requirements applicable to these parts in this Recommendation, with the possibility, as far as the meter is concerned, to refer only to the relevant OIML Recommendations without taking into account the conditions of installation for example.

*3 To the complete measuring system*

In this case they should refer to all the relevant parts of this Recommendation applicable for the type of measuring system, and decide which types of measuring systems are subject to legal control (energy or mass or volume at base conditions).

### 1.2 Preliminary information on the approach

This Recommendation uses new concepts for legal metrology such as the concept of “documented provisions” (see definition in T.1.20) and the quadratic combination of maximum permissible errors applicable to modules in order to determine the maximum permissible error of the measuring system. This concept does not “guarantee” that each measurement fulfils the maximum permissible errors but is consistent with the fact that payment is not based on one single measurement but on a combination of consecutive measurements in the field of gas measurement, and that the probability is very low that all the elements of the system operate at the worst conditions at the same time.

This approach leads us to implement tools that are used in general in the field of uncertainty calculations, but in no case can it be considered that the errors determined in the framework of this Recommendation are uncertainties, nor do they fulfill all the necessary criteria applicable to uncertainty calculations.

This approach must be considered as a conventional one, being a good compromise between a scientific approach and a practical but rigorous approach. It should provide a better idea of the global accuracy of measurements than the result of an arithmetic addition of individual mpes applicable to the components of the measuring system and of their shift of errors under influence quantities for instance.

## 2 Scope of application

This Recommendation applies to measuring systems for gaseous fuel:

- with a designed maximum flowrate  $Q_{\max}$  equal to or greater than 100 m<sup>3</sup>/h at base conditions and for operating pressures equal to or greater than 200 kPa (2 bar) absolute;
- not fitted with diaphragm gas meters.

It may apply to very large measuring systems located at the border between two countries as well as to smaller measuring systems, with the exception of measuring systems for compressed natural gas for vehicles (CNG).

However, the provisions of this Recommendation may be adapted to other cases.

This Recommendation lays down the metrological and technical requirements applicable to the measuring systems subject to legal metrology controls.

Different types of measuring systems are considered:

- measuring systems providing indications of volume at base conditions (as defined in this Recommendation) or mass converted from a volume of gas determined at metering or base conditions;
- measuring systems directly providing the mass of gas;
- measuring systems providing an indication of energy corresponding to a volume at base conditions or a mass of gas.

The concept of a measuring system may involve data and figures provided according to documented provisions. This is often necessary in particular for the determination of energy. In this case the purpose of this Recommendation is to provide tools in order to manage energy on a metrological basis (see examples in D.3). It is not intended to prohibit the use of other tools allowing the management of energy (see examples in D.4).

The conversion of mass to volume is not covered in the scope of this Recommendation; however, it is not intended to eliminate this possibility. In such a case appropriate provisions in this Recommendation have to be adapted. Annex G gives information on this type of conversion.

This Recommendation also provides the way the measuring systems are approved and verified. The requirements for measuring systems are complementary to those applicable only to meters as provided in OIML R 137-1.

This Recommendation does not provide any requirements that are applicable to meters.

### **3 Terminology**

The terminology used in this Recommendation conforms to the *International Vocabulary of Metrology (VIM)*[1] and the *International vocabulary of terms in legal metrology (VIML)*[2]. For the purposes of this Recommendation, the following definitions apply.

*Note:* This terminology shall be considered as part of this Recommendation.

#### **T.1 Measuring system and its constituents**

##### **T.1.1 Meter**

Instrument intended to measure, memorize and display the volume or mass of gas passing through the flow measuring device at metering conditions.

*Note:* The display may be a remote indicating device.

##### **T.1.2 Flow measuring device**

Part of the meter that converts the volume or mass flow of the gas to be measured into signals for the calculator. It includes the sensor and the measuring transducer.

###### **T.1.2.1 Sensor (VIM 3.8)**

Element of a measuring instrument or measuring chain that is directly affected by the measurand.

###### **T.1.2.2 Measuring transducer (VIM 3.7)**

Device that provides an output quantity having a determined relationship to the input quantity.

##### **T.1.3 Calculator**

Part of the measuring system that receives the output signals from the flow measuring device(s) or from another calculator and possibly from the associated measuring instruments, transforms them, and, if appropriate, stores the results in memory until they are used. In addition, the calculator may be capable of transmitting and receiving data from peripheral equipment.

*Note:* A measuring system may have one, two or more calculators, for instance a mechanical calculator to produce the volume at metering conditions and which transmits the value to a mechanical indicating device, an electronic calculator which also calculates the volume at metering conditions, associated with an electronic indicating device, and another one to calculate the converted value.

##### **T.1.4 Indicating device**

Part of a measuring instrument that displays the measurement results.

##### **T.1.5 Ancillary device**

Device, other than the main indicating device, connected to a calculator, intended to perform a particular function, directly involved in elaborating, transmitting or displaying measurement results.



Main ancillary devices are:

- repeating indicating device;
- printing device;
- memory device;
- totalizing indicating device;
- conversion device.

- Notes:*
- 1 An ancillary device may or may not be subject to legal metrology control according to its function in the measuring system or to national regulations.
  - 2 An ancillary device may be integrated into the calculator, into the meter, or constitutes peripheral equipment linked to the calculator by means of an interface.

### **T.1.6 Additional device**

Element or device, other than ancillary, required to ensure correct measurement or intended to facilitate the measuring operations, or which could in any way affect the measurement.

Examples of additional devices are:

- filter;
- flow conditioning device;
- branch or by-pass line;
- valves;
- pressure reduction devices located upstream or downstream of the meter;
- sampling systems;
- piping.

### **T.1.7 Measuring system**

System which comprises the metering module (see T.1.8), and all the ancillary devices and additional devices and, when appropriate, a documented provisions system ensuring the quality and the traceability of data.

### **T.1.8 Metering module**

Subassembly of a measuring system which corresponds to the meter(s) itself (themselves), associated, where applicable, with an additional calculator with a correction and an indicating device, and to all other parts of the gas circuit of the measuring system (in particular additional devices).

### **T.1.9 Associated measuring instrument**

Instrument for measuring certain measurands which are characteristic of the gas (temperature, pressure, calorific value, etc.) and which are used by the calculator with a view to making a correction and/or a conversion.

### **T.1.10 Correction factor (adapted from VIM 2.53)**

Numerical factor (single constant or coming from a mathematical function " $f(q)$ ") by which the uncorrected result is multiplied to compensate for the estimated systematic error.

### **T.1.11 Adjustment and correction devices**

#### **T.1.11.1 Adjustment device**

Device incorporated in the meter that only allows shifting of the relative error curve generally parallel to itself, with a view to bringing errors within the maximum permissible errors and to set the weighted mean error (see T.2.20) at minimum.

#### **T.1.11.2 Correction device**

Device connected to or incorporated in the meter/and or a calculator for automatically correcting the volume at metering conditions, by taking into account the flowrate and/or the characteristics of the gas to be measured (temperature, pressure, gas composition, etc.) and by also taking into account pre-established calibration curves.

*Note:* The characteristics of the gas may either be measured using associated measuring instruments, or stored in a memory in the instrument.

#### **T.1.12 Conversion device**

*Notes:* 1 In this Recommendation the wording “conversion device” covers conversion devices as such, as well as the conversion function in a calculator.

2 A calculator, a correction device and a conversion device may be combined in a single unit.

##### **T.1.12.1 Volume conversion device**

Device which automatically converts the volume measured at metering conditions into a volume at base conditions or into a mass by taking into account the gas characteristics (i.e. pressure, temperature, composition, density) measured using associated measuring instruments or stored in a memory.

The quotient of the volume at base conditions or of the mass to the volume at metering conditions is referred to as the “conversion factor”.

##### **T.1.12.2 Energy conversion device**

Device which automatically multiplies the volume at base conditions or the mass by the representative calorific value of the gas.

#### **T.1.13 Metering conditions**

Conditions of the gas at which the quantity is measured at the point of measurement (temperature and pressure of the measured gas).

#### **T.1.14 Base conditions**

Specified conditions to which the measured quantities of gas are converted.

*Note:* The terms “reference conditions” are frequently used instead of “base conditions”.

#### **T.1.15 (Gross) Calorific value (adapted from ISO 6976)**

Amount of heat which would be released by the complete combustion in air of a specified quantity of gas, in such a way that the pressure at which the reaction takes place remains constant, and all the products of combustion are returned to the same specified temperature as that of the reactants, all of

these products being in the gaseous state except for water formed by combustion, which is condensed to the liquid state at this specified temperature.

- Notes:*
- 1 In the following parts of this Recommendation, calorific value is used for gross calorific value.
  - 2 The condensation enthalpy and combustion enthalpy depend directly upon the temperature and pressure; consequently the energy at base conditions is considered.
  - 3 The calorific value should be determined on a mass or volumetric basis.

#### **T.1.16 Representative calorific value**

Individual calorific value or a combination of calorific values that is considered to be, according to the constitution of the measuring system, the most appropriate calorific value to be associated with the metered quantity in order to calculate the energy.

#### **T.1.17 Calorific value determining device (CVDD)**

Associated measuring instrument for obtaining the calorific value of gas.

#### **T.1.18 Audit trail**

Set of electronic and/or paper records that provide for a complete examination of measured variables, parameter settings and calculation results to check the accuracy of a measurement and any necessary corrections.

*Note:* The required records may include volumes at metering conditions, pressures, temperatures and calorific values, conversion equation specification and parameters, volumes and energy at base conditions, calibration datum, and alarm logs.

#### **T.1.19 Secured communication**

Communication, physical or not, between elements of a measuring system ensuring that information transferred from one of these elements to another may not be tampered with by the user, by external influences or by fault of the system.

*Note:* This is accomplished by sealing devices and/or checking facilities.

#### **T.1.20 Documented provisions**

Provisions established by the user of a measuring system in order to give confidence to the National Authority that operations are performed according to metrological expectations when they are not performed using associated measuring instruments subject to control and/or secured communications.

*Note:* Documented provisions may be part of a quality assurance system.

#### **T.1.21 Compressibility factor**

Parameter which indicates the deviation from the ideal gas (see ISO 12213-1).

*Note:* In general in this Recommendation the ratio  $Z/Z_b$  of compressibility factors respectively at metering and base conditions is used.

#### **T.1.22 Nominal operating conditions**

Normal, average or typical conditions of use of a measuring system or a device provided by the manufacturer.

**T.1.23 Principal measurands**

Volume at metering conditions, volume at base conditions, mass or energy.

**T.2 Metrological characteristics****T.2.1 Primary indication(s)**

Indication(s) (displayed, printed or memorized) which is (are) subject to legal metrological control.

*Note:* Indications other than primary indications are commonly referred to as secondary indications.

**T.2.2 Uncertainty of measurement (adapted from VIM 2.26)**

Parameter, associated with the result of a measurement, that characterizes the dispersion of the values that could reasonably be attributed to the measurand.

**T.2.3 Conventional true value (of a quantity) (VIM 2.12)**

Value attributed to a particular quantity and accepted, sometimes by convention, as having an uncertainty appropriate for a given purpose.

**T.2.4 (Absolute) Error of measurement (VIM 2.16)**

Result of a measurement minus a true value of the measurand.

*Note:* Since a true value cannot be determined, in practice a conventional true value is used.

**T.2.5 Relative error**

Error of measurement divided by a true value of the measurand.

**T.2.6 Maximum permissible error (mpe) (adapted from VIM 4.26)**

Extreme values permitted by this Recommendation for an error.

**T.2.7 Traceability of a measurement (adapted from VIM 2.41)**

Property of the result of a measurement or the value of a standard whereby it can be related to stated references, usually national or international standards, through an unbroken chain of comparisons all having stated uncertainties.

**T.2.8 Specified measuring ranges**

Set of values of measurands or quantities characteristic of the gas for which the error is intended to lie within the limits specified in this Recommendation. In general the upper and lower limits of the specified measuring range are called maximum value and minimum value, respectively (for example: maximum flowrate 2 000 m<sup>3</sup>/h, minimum flowrate 50 m<sup>3</sup>/h).

*Notes:* 1 This definition applies to the measuring system and also to the elements that compose the measuring system.

2 Main measurands or quantities characteristic for the metering module are flowrate, pressure or temperature of the gas.

3 A conversion device has a specified measuring range for each quantity that it processes.

**T.2.9 Maximum flowrate of the measuring system  $Q_{\max}$** 

Flowrate equal to the sum of the flowrates of all the meters in parallel branches (where appropriate) forming the system when one of these meters reaches its maximum flowrate under the specified conditions of use, all meters being in use.

**T.2.10 Minimum flowrate of the measuring system  $Q_{\min}$** 

Flowrate equal to or greater than the smallest “minimum flowrate” of the individual meters.

**T.2.11 Minimum measured quantity**

Smallest quantity for which the measurement is metrologically acceptable for that system.

*Note:* A measuring system has a minimum measured quantity for each principal measurand it processes (volumes, mass or energy).

**T.2.12 Minimum specified quantity deviation**

Positive maximum permissible error for a minimum measured quantity of a measuring system or a metering module.

**T.2.13 Repeatability error (adapted from VIM 2.21)**

For the purpose of this Recommendation: difference between the largest and the smallest results of successive measurements of a same quantity carried out under the same conditions.

**T.2.14 Intrinsic error**

Error determined under reference conditions.

**T.2.15 Initial intrinsic error**

Intrinsic error as determined prior to all performance tests.

**T.2.16 Fault**

Difference between the error of indication and the intrinsic error of a measuring system or of its constituent elements.

**T.2.17 Significant fault****T.2.17.1 For the principal measurands (volumes, mass or energy)**

Fault, the magnitude of which is greater than one tenth of the magnitude of the maximum permissible error for the relevant measurand. However, whatever is the measured quantity:

- faults greater than one tenth of the magnitude of the maximum permissible error corresponding to a quantity equal to one minute at  $Q_{\max}$  are always considered as significant,
- faults smaller than the relevant minimum specified quantity deviation are never considered as significant.

*Notes:* 1 For the principal measurands this concept applies only to the electronic parts of the measuring system (in general the calculator) but not to the meter as such. Meters shall be tested and assessed according to the specific applicable OIML International Recommendation(s).

- 2 The significant fault for a calculator is calculated on the basis of the maximum permissible error applicable to the principal measurand and not on the basis of the maximum permissible error applicable to the calculator.
- 3 When a device is used for measuring two or more principal measurands (a calculator for example), it has a significant fault for each measurand.

#### **T.2.17.2 For associated measuring instruments other than CVDDs**

Fault, the magnitude of which is greater than half of the magnitude of the maximum permissible error for the relevant measurand. However a fault, the magnitude of which is smaller than 2 scale intervals of the associated measuring instrument is never considered as a significant fault.

*Note:* For associated measuring instruments other than CVDDs this concept applies to the whole associated measuring instrument, or to the electronic part only, according to what is subject to the test.

#### **T.2.17.3 For CVDDs**

Fault, the magnitude of which is greater than one fifth of the magnitude of the maximum permissible error for the calorific value. However a fault, the magnitude of which is smaller than 2 scale intervals of the CVDD is never considered as a significant fault.

*Note:* For CVDDs this concept applies to the whole device.

#### **T.2.17.4 The following faults are not considered as significant:**

- faults resulting from simultaneous causes independent from each other within the instrument itself or within its checking facility;
- temporary faults resulting from momentary indication variations, but which cannot be interpreted, stored or transmitted as measurement results.

#### **T.2.18 Drift (VIM 5.16)**

Slow change in a metrological characteristic of a measuring instrument.

#### **T.2.19 Installation effect**

Any difference in performance of the metering module arising between the calibration under ideal conditions and actual conditions of use. This difference may be caused by different flow conditions due to velocity profile, perturbations, or by different working regimes (pulsation, intermittent flow, alternating flow, vibrations, etc.).

#### **T.2.20 Weighted mean error (WME)**

Weighted combination of errors of a meter or a metering module. The *WME* is used to adjust the error curve as close as possible to zero. The *WME* is calculated as follows:

$$WME = \frac{\sum_{i=1}^n k_i \times E_i}{\sum_{i=1}^n k_i}$$

Where:

- $n$  greater than or equal to 6 being the number of measurements  $i$  performed at different flowrates  $Q_i$ ;
- $k_i$  being the weighting factors;
- $E_i$  being the error at the flowrate  $Q_i$ .

For each flowrate,  $k_i = Q_i/Q_{\max}$ , except for  $Q_i = Q_{\max}$  for which the weighting factor is equal to 0.4.

*Note:* When the specified measuring range of a metering module including only one meter is known beforehand and when this range is smaller than the maximum specified measuring range of the meter, it is recommended to determine the *WME* and adjust the meter over the actual operating range only and update the markings accordingly.

### **T.2.21 Durability**

Capability of an electronic part of the measuring system to keep its performance characteristics over a period of use.

### **T.2.22 Adjustment interval for a calorific value determining device**

Time interval or number of measurements between two necessary adjustments of a calorific value determining device.

## **T.3 Tests and test conditions**

### **T.3.1 Influence quantity (VIM 2.7)**

Quantity that is not the measurand but which affects the result of the measurement.

### **T.3.2 Influence factor**

Influence quantity having a value within the rated operating conditions of the measuring system as specified in this Recommendation.

### **T.3.3 Disturbance**

Influence quantity outside the specified rated operating conditions of the measuring system.

*Note:* An influence quantity is a disturbance if for that influence quantity the rated operating conditions are not specified.

### **T.3.4 Rated operating conditions (adapted from VIM 4.9)**

Conditions of use giving the range of values of influence quantities for which the metrological characteristics are intended to lie within the maximum permissible errors.

### **T.3.5 Reference conditions (adapted from VIM 4.11)**

Set of reference values or reference ranges of influence factors prescribed for testing the performance of a measuring system or a device or for intercomparisons of the results of measurements.

### **T.3.6 Performance test**

Test intended to verify whether the measuring equipment under test (EUT) is capable of accomplishing its intended functions.

### **T.3.7 Endurance test**

Test intended to verify whether the metering module is able to maintain its performance characteristics over a period of use.

## **T.4 Electronic or electrical equipment**

### **T.4.1 Electronic device**

Device employing electronic sub-assemblies and performing a specific function. Electronic devices are usually manufactured as separate units and are capable of being tested independently.

- Notes:*
- 1 The electronic parts of CVDDs are not tested separately.
  - 2 A measuring system including at least one electronic device subject to legal control is called an electronic measuring system.

### **T.4.2 Checking facility**

Facility that is incorporated in a measuring system and which enables significant faults to be detected and acted upon.

*Note:* The checking of a transmission device aims at verifying that all the information which is transmitted (and only that information) is fully received by the receiving equipment.

### **T.4.3 Automatic checking facility**

Checking facility that operates without the intervention of an operator.

### **T.4.4 Permanent automatic checking facility (type P)**

Automatic checking facility operating continuously during the entire measurement operation.

### **T.4.5 Intermittent automatic checking facility (Type I)**

Automatic checking facility intervening at certain time or quantity intervals.

### **T.4.6 Non-automatic checking facility (Type N)**

Checking facility that requires the intervention of an operator.



## 4 Description

As a general rule, according to the maximum flowrate of a measuring system as well as according to technical and economical considerations, the National Authorities may impose:

- the accuracy class;
- the type of conversion (see 7.3.2);
- the components to be included in the measuring system. Subclause D.3.1 provides suggestions for this purpose.

### 4.1 Components of a measuring system

4.1.1 A meter itself is not a measuring system or a metering module.

A measuring system may include elements of the following non exhaustive list:

- meter(s) or metering module;
- checking facilities;
- metrological seals;
- conversion devices; (\* if applicable)
- caloric value determining device; (\* if applicable)
- memory or printing device and automatic chronological recorder; (\* according to national regulation)
- switching equipment to select the appropriate number of meter lines corresponding to the real load of the station and used to ensure that any meter in service is measuring flows between its  $Q_{\min}$  and  $Q_{\max}$ ; (\*)
- gas sampling extraction and conditioning system; (\* if applicable)
- provision for the calibration of the calorific value determining device including calibration standards; (\* if applicable)
- isolating valves; (\*\*)
- additional piping and fittings; (\*\*)
- filter and separator; (\*\*)
- gas pre-heating equipment; (\*\*)
- equipment to reduce the noise level; (\*\*)
- flow and pressure control equipment for the station or the metering line; (\*\*)
- equipment to prevent the formation of hydrates and ice; (\*\*)
- equipment to absorb vibrations and pulsations; (\*\*)
- flow profile conditioning device; (\*\*)
- other components; (\*\*)
- documented provisions and quality assurance systems. (\*\*\*)

\* is always part of the measuring system when present

\*\* is part of the measuring system when there is a risk it influences the performance of the measuring system

\*\*\* is part of the measuring system when necessary to ensure the integrity and/or the correct operation of the measuring system

4.1.2 If several meters and/or flow measuring devices are intended for a single measurement operation, these meters are considered to be included in the same metering module or measuring system.

If several meters and/or flow measuring devices intended for separate measuring operations (different contracts) do have elements in common (calculator, filters, conversion device, etc.), each meter and/or flow measuring device is considered to make up, together with the common elements, one metering module or measuring system.

## 4.2 Concept of a measuring system

According to the way in which relevant characteristics of the gas are collected, a measuring system may consist of (see D.1):

- 1 Separate modules (metering module, conversion device, calorific value determining device, etc.) which fulfill the requirements for each module present and whose modules are connected via secured communications ensuring reliable transmission of data.
- 2 Separate modules which fulfill the requirements for each module present but whose modules are not connected via secured communications ensuring reliable transmission of data.

In this case documented provisions shall ensure the traceability of data used for the determination of the corresponding measurands.

- 3 Separate modules which fulfill the requirements for each module present and the requirements for taking into consideration data that are not measured (for instance the pressure of the gas in the case of converted volume) or that are not locally measured (for instance the calorific value of the gas in the case of remote determination).

In this case documented provisions shall ensure:

- the representativeness of the data taken into account; and
- the traceability of data used for the determination of the corresponding measurands.

A combination of cases 2 and 3 is possible.

The legal authority may decide that the metrological control applies to each of the above types of measuring systems, or only to certain types.

## 4.3 Flow measurement

Several different principles of physics may be used to determine the gas quantities (see D.2).

## 5 Units of measurement and abbreviations

### 5.1 Units of measurement

The volume shall be indicated in cubic meters. The mass shall be indicated in tonnes or kilograms. The energy shall be indicated in joules and/or kilowatt-hours. The calorific value shall be indicated in one of these units per unit of mass or volume at base conditions. For measurements provided by other associated measuring instruments, the list of SI units shall be referred to.

### 5.2 Abbreviations

For flowrates:

- $Q_{\min}$ : minimum flowrate
- $Q_{\max}$ : maximum flowrate

For ambient temperature:

- $T_{\text{am.min}}$ : minimum value of the range
- $T_{\text{am.max}}$ : maximum value of the range

For gas temperature:

- $T_{\min}$ : minimum value of the range
- $T_{\max}$ : maximum value of the range

For gas pressure:

- $P_{\min}$ : minimum value of the range
- $P_{\max}$ : maximum value of the range

For supply electricity:

- $U_{\text{nom}}$ : nominal value for supply voltage
- $F_{\text{nom}}$ : nominal value of supply frequency

*WME*: weighted mean error

*mpe*: maximum permissible error

*CV*: calorific value (symbol *Hs*)

*CVDD*: calorific value determining device

*MMQ*: minimum measured quantity for volumes or mass

*MMQ<sub>e</sub>*: minimum measured quantity for energy

*E<sub>min</sub>*: minimum specified quantity deviation

## 6 Metrological requirements

### 6.1 Accuracy classes

Measuring systems are classified into three accuracy classes: A, B, C.

### 6.2 Maximum permissible errors (mpes) for measuring systems

6.2.1 The maximum permissible relative errors, positive or negative, for measuring systems are specified in Table 1. These values are applicable for type approval and for initial verification.

**TABLE 1**  
**mpes for measuring systems**

Maximum permissible errors on determining:	Accuracy class A	Accuracy class B	Accuracy class C
Energy	± 1.0 %	± 2.0 %	± 3.0 %
Converted volume, converted mass or direct mass	± 0.9 %	± 1.5 %	± 2.0 %

6.2.2 However, the magnitude of the maximum permissible error (after calculation as an absolute value) shall be equal to or greater than the minimum specified quantity deviation  $E_{\min}$  which is given by the formula:

$$E_{\min} = 2 \times MMQ \times mpe$$

Where:

*MMQ* is the minimum measured quantity for the relevant measurand;

*mpe* is the relevant value in the table.

### 6.3 mpes for modules

#### 6.3.1 General

6.3.1.1 The maximum permissible errors, positive or negative, for modules (parts or functions as stated in Table 2) are specified in Table 2. These values are applicable at type approval and at initial verification.

**Table 2 - mpes for modules**

Maximum permissible errors on:	Accuracy class A	Accuracy class B	Accuracy class C
Measuring volume at metering conditions (see 6.3.2)	± 0.70 %	± 1.20 %	± 1.50 %
Converting into volume at base conditions or into mass (see 6.3.3)	± 0.50 %	± 1.00 %	± 1.50 %
Calorific value measurement (only CVDD) (see 6.3.4)	± 0.50 %	± 1.00 %	± 1.00 %
Representative calorific value determination (see 6.3.4)	± 0.60 %	± 1.25 %	± 2.00 %
Converting into energy (see 6.3.4)	see 6.5	see 6.5	see 6.5

6.3.1.2 However, for volume at metering conditions the magnitude of the maximum permissible errors (after calculation as an absolute value) shall be equal to or greater than the minimum specified quantity deviation  $E_{\min}$  which is given by the formula:

$$E_{\min} = 2 \times MMQ \times mpe$$

Where:

$MMQ$  is the minimum measured quantity;

mpe is the relevant value in the table.

6.3.1.3 Moreover, when conformity to Table 1 cannot be verified directly, the conformity of the measuring system is assessed by calculation. By convention and where applicable, the global maximum permissible error of a measuring system is equal to the square root of the sum of the squares of the maximum permissible errors of the following modules (see Annex C for an example):

- metering module (measuring the quantity at metering conditions);
- converting this quantity into volume at base conditions or into mass;
- CV determination.

### **6.3.2 Measuring volume at metering conditions**

Maximum permissible errors on measuring volume at metering conditions apply to type approval or initial verification where:

- the meter is corrected (or  $WME$  set at its minimum) where necessary or applicable;
- the meter is adjusted at nominal operating conditions;
- installation effects are taken into account (see Annex B).

When a metering module is subject to a first stage verification (before verification on site or if this verification is considered sufficient by the authority - see 10.3) mpes for this verification are calculated according to the formula in B.6.1.

*Note:* The mpes applicable to metering modules, specified for volume or mass measurements, may be smaller than the corresponding values specified in other Recommendations applicable to meters (see also 7.2.1.1). As a consequence, a correction device added to the meter may be necessary.

### **6.3.3 Converting into volume at base conditions or into mass**

Maximum permissible errors on converting into volume at base conditions or into mass may be verified either on the basis of one of the two modular approaches as stated in 6.3.3.1 or 6.3.3.2, or on the basis of a global approach as stated in 6.3.3.3. These three approaches are considered as being equivalent and conversion devices assessed according to 6.3.3.1 or 6.3.3.2 are considered as fulfilling the global requirements for conversion devices in 6.3.3.3.

In the three cases when some characteristics of the gas are not measured using associated measuring instruments (pressure or compressibility factor in particular), this shall be taken into consideration in order to determine that the requirement on the conversion in Table 2 is fulfilled.

Where necessary, the conventional true compressibility factor shall be calculated according to ISO 12213 [9,10,11].

### 6.3.3.1 First modular approach

In the first modular approach, the associated measuring instruments and the calculations are verified separately. Each associated measuring instrument is verified globally (Table 3-1), using the indication available on the conversion device. The verification of the calculation consists in verifying the calculation concerning each characteristic quantity of the gas (6.3.3.1.1) and the calculation for the conversion (6.5).

The associated measuring instruments may be approved to operate with one or several types of conversion device in order to ensure the compatibility of the association.

Conversion devices which satisfy the provisions in 6.3.3.1.1, 6.3.3.1.2 and 6.5 are considered to fulfill the corresponding requirement laid down in Table 2 (taking into consideration the general statement in the introduction of 6.3.3 if only temperature is measured).

6.3.3.1.1 The mpes applicable to the relevant associated measuring instruments are laid down in Table 3-1. These values are applicable at type approval and at initial verification.

**Table 3-1 mpes for associated measuring instruments other than CVDDs**

Maximum permissible errors on:	Accuracy class A	Accuracy class B	Accuracy class C
Temperature	$\pm 0.5 \text{ }^{\circ}\text{C}$	$\pm 0.5 \text{ }^{\circ}\text{C}$	$\pm 1 \text{ }^{\circ}\text{C}$
Pressure	$\pm 0.2 \%$	$\pm 0.5 \%$	$\pm 1 \%$
Density	$\pm 0.35 \%$	$\pm 0.7 \%$	$\pm 1 \%$
Compressibility factor	$\pm 0.3 \%$	$\pm 0.3 \%$	$\pm 0.5 \%$

6.3.3.1.2 The maximum permissible errors on the calculation of each characteristic quantity of the gas, positive or negative, are equal to one fifth of the relevant value specified in Table 3-1.

### 6.3.3.2 Second modular approach

In the second modular approach, the associated measuring instruments and the calculations are also verified separately, but each associated measuring instrument is verified globally (Table 3-1), using the indication available on the associated measuring instrument itself. This indication shall correspond to that which is directly processed for the converted volume. Then the verification of the calculation consists only in verifying the calculation for the conversion (6.5).

In this case the associated measuring instruments deliver a digital signal. They may be considered as interchangeable provided the type examination certificate provides all the necessary conditions of compatibility with the calculator of the conversion device.

Conversion devices using associated measuring instruments delivering a digital signal directly processed for the conversion and which satisfy the provisions in 6.3.3.1.2 and which satisfy 6.5 are considered to fulfill the corresponding requirement laid down in Table 2 (taking into consideration the general statement in the introduction of 6.3.3 if only temperature is measured).

These values are applicable at type approval and at initial verification.

### 6.3.3.3 Global approach

In this approach the conversion device (i.e. the calculator associated with the associated measuring instruments) is tested as a whole.

Conversion devices which satisfy the provisions in Table 3-2 are considered to fulfill the corresponding requirement laid down in Table 2 (taking into consideration the general statement in the introduction of 6.3.3 if only temperature is measured).

**Table 3-2 mpes on volume at base conditions or mass for conversion devices tested as a whole**

Test conditions and types of conversion:	Accuracy class A	Accuracy class B	Accuracy class C
Tests at reference conditions for all types of conversion	0.3 %	0.5 %	0.7 %
Tests at rated operating conditions for conversion devices performing as a function only of temperature	- (Not relevant)	0.7 %	1.0 %
Tests at rated operating conditions for other conversion devices	0.5 %	1.0 %	1.5 %

### 6.3.4 Converting into energy and determination of the calorific value

In order to determine the errors on the calorific value (CV), the conventional true CV shall be calculated according to ISO 6976 [12].

6.3.4.1 Converting into energy results in the multiplication of the mass or converted volume by the representative calorific value.

The mpes on the multiplication are those given in 6.5. As these mpes are small compared to the mpes applicable for the determination of the CV, they need not be taken into account in the final calculation of the error on energy.

6.3.4.2 According to the description of possible measuring systems laid down in 4.2, the determination of the CV may necessitate documented provisions. This is the case when the CV is not determined locally (at the same place as the metering module) and/or when the CV is not continuously measured and associated with the metered quantity without a shift in time.

As a consequence and by definition, the error in converting into energy results in the following possible components:

- the error of the calorific value determining device (CVDD);
- the (expanded) uncertainty resulting from the fact that the CV is not perfectly stable and is not continuously measured,  $U_C$ ;
- the (expanded) uncertainty resulting from the fact that the CV is not associated with the metered quantity without a shift in time,  $U_T$ ;
- the (expanded) uncertainty resulting from the fact that the CV is not locally determined,  $U_L$ ;
- other possible components of uncertainties,  $U_O$ .

The estimation of expanded uncertainties should be made according to the *Guide to the expression of uncertainty in measurement* (GUM) [7]. The way these components are determined and combined in order to calculate the error on converting into energy is laid down in 7.4.2.

6.3.4.3 For classes A and B, the mpes on the determination of the representative CV are slightly larger than the maximum mpes for a CVDD. This is necessary at least because of the component of uncertainty  $U_C$ . Practical consequences of the figures in Table 2 in general lead to the following:

- a class A measuring system involves one (or more for better accuracy) local class A CVDD(s);
- a class B measuring system involves either one or more class A CVDD(s) in general associated with the relevant documented provisions or one or more local class B CVDD(s);
- a class C measuring system involves one or more class A or class B CVDD(s) associated with the relevant documented provisions.

## 6.4 Other metrological performances of a CVDD

Requirements from 6.4.1 through 6.4.6 and 6.4.9 apply to all types of CVDDs. In addition, the provisions in 6.4.7 and 6.4.8 give additional requirements for specific types of CVDDs.

### 6.4.1 General requirement

The complete CVDD (not only the electronic part) shall fulfill the general requirements specified in 9.1.

### 6.4.2 Repeatability

The repeatability error (as defined in T.2.13) of the CVDD shall be smaller than or equal to one fifth of the magnitude of the mpe that would be applicable to the mean value of the measurement results.

### 6.4.3 Adjustment interval and drift

The drift at the end of the adjustment interval shall be smaller than or equal to half of the magnitude of the mpe. The adjustment interval and the adjustment procedure shall be specified by the manufacturer.

For CVDDs fitted with an automatic internal adjustment means, the means shall not be likely to drift and either the adjustment shall be performed automatically at the end of the adjustment interval or a warning calling for adjustment shall be generated automatically at the end of the adjustment interval.

### 6.4.4 Influence of the gas composition

The manufacturer shall specify the characteristics (limits of chemical composition) of the gas to be measured.

For gases of the same calorific value, the influence of the composition shall be smaller than or equal to two-fifths (2/5) of the magnitude of the mpe.

*Note:* It is assumed that the uncertainties of the CV of the calibration gases are consistent with the requirement.

### 6.4.5 Response time

The following provisions are applicable to the CVDD itself and not to the CVDD complemented with the sampling line.

*Note:* The delay due to the sampling line has to be considered as included in the uncertainty component  $U_T$  (shift in time).

For any instantaneous change in calorific value at least equal to 5 MJ within the measuring range, the change in indication after 1 h shall be at least 99 % of the effective variation. As a consequence, the measuring range shall be at least 5 MJ.



#### **6.4.6 Influence of gas supply**

The manufacturer shall provide reference conditions and rated operating conditions for:

- supply gas(es) pressure,
- supply gas(es) flowrates.

#### **6.4.7 Specific provisions applicable to calorimeters**

##### **6.4.7.1 Influence of atmospheric pressure**

The CVDD shall be designed and manufactured so that it continues to operate as designed and so that its errors do not exceed the maximum permissible errors when it is subject to variations in atmospheric pressure.

The corresponding rated operating conditions shall be specified by the manufacturer.

##### **6.4.7.2 Installation effects**

The manufacturer shall provide any necessary information on the capability of the calorimeter to be subject to ambient air movements (draughts). The type approval certificate states any appropriate information.

#### **6.4.8 Specific provisions applicable to gas chromatographs**

A gas chromatograph shall be capable of measuring at least the following components:

- nitrogen;
- carbon dioxide;
- methane;
- ethane;
- propane;
- iso-butane;
- n-butane;
- n-pentane;
- iso-pentane;
- neo-pentane;
- hexanes and superior.

If the manufacturer claims that a gas chromatograph is capable of measuring more components than those listed above, calibration gases shall be chosen accordingly. The measuring range shall be specified by the manufacturer. It shall not start at zero and shall not be nil.

#### **6.4.9 Other influences for all technologies**

The manufacturer shall declare other influences that have been identified. This declaration is checked at type approval taking into consideration the state of the art. To this end it is considered that an influence smaller than one-fifth (1/5) of the magnitude of the mpe is not significant.

Any significant influence (taking into consideration the state of the art) shall be specified in the type approval certificate, accompanied by relevant information.

In general the influence of the natural gas relative humidity is not relevant for technologies other than the stoichiometric principle.

Taking the above information into consideration, at type approval, initial verification or further verification, the Authority may:

- refuse the proposed CVDD if it does not suit the real situation of the measuring system; or
- require significant influences to be taken into account in the uncertainty calculation; or
- test other possible influences if it considers that the state of the art has not been respected (only at type approval).

### **6.5 mpes for calculators**

Maximum permissible errors, positive or negative, on the calculation of quantities of gas, applicable to electronic calculators are equal to 0.05 % of true calculated value.

*Note:* This requirement is applicable to any calculation and not only to the conversion calculation.

### **6.6 Repeatability error of a metering module**

For any quantity greater than or equal to the volume or mass corresponding to five minutes at  $Q_{max}$ , the repeatability error of the metering module shall be smaller than or equal to one-fifth (1/5) of the value specified in the first line of Table 2 (see test conditions in 10.2.7.3).

### **6.7 Endurance of a metering module**

For a given gas, if applicable within their specified measuring ranges, metering modules shall present a magnitude of the variation of the estimated systematic errors after the endurance test less than one-quarter (1/4) of the mpe for the volume at metering conditions specified in the first line of Table 2 (see test conditions in 10.2.6.2.4).

### **6.8 Maximum permissible errors for in service instruments or subsequent verifications**

The mpes for “in service” measuring systems and elements of measuring systems or at subsequent verifications should not exceed 1 to 2 times (ratio to be set by the National Authority) the value permitted at initial verification.

*Note:* If the national regulation specifies mpes applicable to meters in addition to mpes applicable to measuring systems and elements of measuring systems as specified in this Recommendation, mpes applicable to meters should conform to the appropriate International Recommendation and/or international or regional standard, if provided in these documents.

## 7 Technical requirements for measuring systems

### 7.1 General

National regulations should state that taking advantage of mpes or other tolerances in this Recommendation is prohibited and accordingly be prepared to take appropriate actions, in particular concerning:

- the policy concerning the choice and use of calibration means;
- the adjustment of metering modules using adjustment or correction devices for adjusting respectively the *WME* or the errors to values other than those that are as close as practical to zero, even when the errors are within the maximum permissible errors;
- the adjustment and use of CVDDs.

#### 7.1.1 Ancillary devices

7.1.1.1 Where ancillary devices are made compulsory by this Recommendation or by a national or international regulation, they are considered as integral parts of the measuring system and are therefore subject to metrological control and shall conform to the provisions of this Recommendation.

7.1.1.2 When the ancillary devices are not subject to metrological control, the measuring system shall be examined to ensure that these ancillary devices do not affect the metrological performance of the measuring system. In particular, the system shall continue to operate correctly and its metrological functions shall not be affected when any kind of peripheral equipment, in particular an ancillary device, is connected (or disconnected).

In addition, these devices shall bear a legend which is clearly visible to the user to indicate that they are not controlled when they indicate a measurement result which is visible to the user.

#### 7.1.2 Specified measuring ranges

7.1.2.1 The measuring ranges (flowrates, temperature, pressure, etc.) of a measuring system shall be included within the measuring ranges of each of its components.

7.1.2.2 Where several meters are operated in parallel in a metering module, the limiting flowrates ( $Q_{\max}$ ,  $Q_{\min}$ ) of the different meters should be taken into account.

7.1.2.3 The measuring range shall satisfy the conditions of use of the metering module; the latter shall be designed so that the flowrate is between the minimum and maximum flowrates, except during standstill.

The ratio  $Q_{\max}/Q_{\min}$  for the metering module shall be specified by the manufacturer.

#### 7.1.3 Rated operating conditions

7.1.3.1 The conditions applied to measuring systems are divided into three groups:

- climatic conditions;
- mechanical conditions;
- electrical and electromagnetic conditions.

The classification is given in Annex A. The classes shall be in accordance with the conditions of use of the measuring systems.

The environmental range of a measuring system shall be included within the environmental range of each of its components.

- Notes:*
- 1 Different environmental classes may apply to a measuring system. Not all components are installed in the same location for example: meters may be located in an open air facility while the electronic calculators may be located in a climatically controlled room.
  - 2 Applicable classes shall be determined at type approval and suitability for use shall be controlled at initial and subsequent verifications of the measuring system.

7.1.3.2 The rated operating conditions are specified in Annex A for each influence factor.

#### **7.1.4 Indications**

7.1.4.1 According to the type of measuring system, the final results are expressed in terms of:

- volume (at base conditions) or mass;
- energy that is the result of multiplying the gas quantity by the representative calorific value of the gas.

The symbol or the name of the unit shall appear in the immediate vicinity of the indication.

7.1.4.2 The measuring system shall be provided with devices capable of indicating measurement results (indicating, printing or memory devices) the total quantity (volume, mass or energy) and at least, for each meter line where appropriate, the following information:

- the volume at base conditions, the mass or the energy;
- the gas quantity at metering conditions;
- the corrected quantity, if applicable;
- the correction values, if applicable;
- the calorific value, if applicable;
- the quantities measured by other associated measuring instruments (for example: pressure, temperature, and composition);
- the alarm indications;
- the conversion factor, if applicable;
- the ratio of the compressibility factors  $Z/Z_b$ ;
- any input data affecting the metrological results.

7.1.4.3 The use of the same display for the indications of volume at metering conditions, of volume at base conditions, of mass or energy is authorized provided that the nature of the displayed quantity is clear and that these indications are available on request.

The energy or, when not available, the volume at base conditions or the mass shall be preferably displayed. This relevant quantity shall be displayed permanently or shall be capable of being displayed by special command.

7.1.4.4 A measuring system may have several devices indicating the same quantity. Each shall meet the requirements of this Recommendation if they are mandatory or necessary. The scale intervals of the various indications may be different.

7.1.4.5 For any measured quantity relating to the same measurement and measurand, the indications provided by various devices shall not deviate one from another by more than one scale interval or the greater of the two scale intervals if they differ.

7.1.4.6 Primary indications of volumes, mass and energy (when applicable) shall be available up to the settlement of the transaction. National Authorities may prescribe a duration for the availability of these indications.

Moreover, when a printing or memory device is required or used to ensure this availability, there shall be provisions to allow for automatic printing or memorizing at predetermined time intervals. The printing and/or memory device(s) shall be capable of printing and/or memorizing thermodynamic

parameters, totals, starting and ending time of the various alarms as well as all relevant information to establish the chronology of the metering events for example printed sheet numbering, date, hour, etc.

## **7.2 Metering module**

### **7.2.1 General**

7.2.1.1 The meter(s) of a metering module shall comply with applicable International Recommendations when these exist, unless otherwise indicated in this Recommendation. The maximum permissible errors laid down in this Recommendation are applicable to the metering module and not to the meter alone.

7.2.1.2 The construction of the metering module shall allow installation of individual meters that conform to the assembling requirements.

Gas meters shall be mounted in the pipeline, according to:

- the provisions laid down in the type approval certificate of the metering module if the latter has been provided;
- the provisions of applicable ISO Standards;
- the manufacturer's instructions and in general;
- the requirements of this Recommendation.

7.2.1.3 If the gas is likely to flow in both directions the metering module shall be designed and controlled in order to perform accurate measurements in both directions and shall record corresponding quantities separately. If the metering module is not designed and controlled in order to perform accurate measurements in both directions, the flow direction shall be clearly marked and the metering module shall be fitted with a non-return device if necessary.

7.2.1.4 If a meter is likely to be overloaded given the supply conditions, a flow limiting device shall be provided. This device shall be installed downstream of the meter. It shall be possible to seal it (see 7.6). The flow limiting device may be mechanical or electronic.

7.2.1.5 Valves that may influence the accuracy of measurements shall be fitted with provisions for sealing.

7.2.1.6 Any additional device connected to the metering module shall be designed so that it does not interfere with the accuracy of the metering process. The meter shall be isolated from the gas pulsations generated, for instance, by a flow regulator or a gas compressor (see B.2 in particular).

7.2.1.7 If the system is fitted with heating devices upstream of the metering lines, a device shall keep the temperature within an acceptable operating temperature range, according to the conversion device used.

### **7.2.2 Parallel branches**

7.2.2.1 Given the specified measuring range of the flowrate it may be necessary to consider several branches in parallel. Meters placed in parallel measuring branches shall not be able to influence the metrological characteristics of each other.

7.2.2.2 National Authorities may decide that the metrological control requires a number of parallel lines so that the maximum flow can be measured when any one line is at a standstill while the other lines are working within their specified limits.

7.2.2.3 If there is a possibility to put parallel lines in series, the connections shall be arranged on the main pipes upstream and downstream of the straight lines required upstream and downstream of the meter. Generally, one isolation valve has to be placed upstream and another downstream (for instance, a stop valve with venting to the air) for each line.

7.2.2.4 Metering modules shall have provisions to select parallel branches so that the flowrate in each branch lies between  $Q_{\max}$  and  $Q_{\min}$  of the meter. The connection or disconnection of the parallel branches may be manual or automatic.

7.2.2.5 The design shall have provisions to avoid any gas flow, actual or fictive, through closed branches. This may involve mechanical and/or checking facilities.

### **7.2.3 By-passing**

7.2.3.1 The contractual availability of the gas flow could require the station to be by-passed.

When the metering module is by-passed, the beginning and ending time of this operation shall be recorded.

7.2.3.2 When rapid action valves are integrated into the installation, an equilibrium by-pass with a small diameter shall be provided. The by-pass should be controlled by a throttle valve facilitating the process of putting the meter and the associated piping under pressure and preventing the gas meter from being damaged.

### **7.2.4 Test possibility on site**

The National Authority may require provisions to be made for using any recognized method for checking and/or verifying the metering module on site in particular metering modules with  $Q_{\max}$  equal to or greater than 10 000 m<sup>3</sup>/h at base conditions (or equivalent for mass).

## **7.3 Converting into volume at base conditions or mass**

The text of this subclause is mainly applicable to the conversion devices for which the conversion calculations are made numerically by means of an electronic calculator. Similar concepts may be applied by analogy to other types of conversion devices.

### **7.3.1 Base conditions**

The following base conditions are preferred by some ISO standards: 101.325 kPa and 288.15 K to determine the volume, and 288.15 K to determine the calorific value. Conversion to other conditions may be conducted in accordance with the relevant ISO or national standards.

### **7.3.2 Types of conversions**

Six types of conversion are dealt with in this Recommendation:

- volume conversion as a function of temperature only (called T conversion);
- volume conversion as a function of the pressure and of the temperature with constant compressibility factor (called P T conversion);
- volume conversion as a function of the pressure, the temperature and taking into account the compressibility factor (called P T Z conversion);
- volume conversion as a function of the density (density conversion);
- mass conversion as a function of volume and density at metering conditions;
- mass conversion as a function of volume and density at base conditions.

The connections between the calculator and the measuring transducers, if they exist, are elements of the conversion device.

This Recommendation deals with tested conversion devices as one instrument, or as a calculator and its associated measuring instruments.

### 7.3.2.1 Volume conversion as a function only of temperature (T conversion)

In this case the conversion device consists in a calculator and a temperature transducer and it converts the volume  $V$  at metering conditions and temperature  $T$  to the base conditions ( $P_b$ ,  $T_b$ ,  $Z_b$ ).

The volume at base conditions  $V_b$  is obtained by the relationship:

$$V_b = K \times \frac{1}{T} \times V$$

$K$  is a fixed value obtained by the relationship:

$$K = \frac{P}{P_b} \times T_b \times \frac{Z_b}{Z}$$

The pressure and  $Z$  are not measured, but shall be included as fixed values in the processing of the conversion factor.

### 7.3.2.2 Volume conversion as a function of pressure and temperature (PT conversion)

In this case the conversion device consists of a calculator, a pressure transducer and a temperature transducer. The compressibility factor may be considered as a fixed value calculated from mean metering conditions and a mean gas composition.

The volume at base conditions is obtained by the relationship:

$$V_b = K' \times \frac{P}{T} \times V$$

$K'$  is a fixed value obtained by the relationship:

$$K' = \frac{1}{P_b} \times T_b \times \frac{Z_b}{Z}$$

$Z$  is not measured, but shall be included as a fixed value in the processing of the conversion factor.

### 7.3.2.3 Volume conversion as a function of pressure, temperature and deviation from the perfect gas law (PTZ conversion)

In this case, the conversion device consists of a calculator, a pressure transducer, a temperature transducer and optional associated measuring instruments measuring gas compressibility.

The deviation from the ideal gas law is compensated by the measurement or calculation of the compressibility factor using an appropriate equation as a function of pressure, temperature and gas properties.

Non measured gas parameters used for the compressibility calculation can be preset at installation time.

The volume at base conditions is obtained by the relationship:

$$V_b = \frac{P}{P_b} \times \frac{T_b}{T} \times \frac{Z_b}{Z} \times V$$

### 7.3.2.4 Volume conversion as a function of density (density conversion)

In this case, the conversion device consists of a calculator and a density transducer.

The volume at base conditions  $V_b$  is obtained by the relationship:

$$V_b = \frac{V \times \rho}{\rho_b}$$

Where:

$V$ : volume at metering conditions

$\rho$ : density at metering conditions

$\rho_b$ : density at base conditions

$\rho_b$  is provided in ISO 6976 [12].

### **7.3.2.5 Mass conversion as a function of volume and density at metering conditions**

In this case, the conversion device consists of a calculator and a density transducer.

The mass  $M$  is obtained by the relationship:

$$M = V \times \rho$$

Where:

$V$ : volume at metering conditions

$\rho$ : density at metering conditions

### **7.3.2.6 Mass conversion as a function of volume and density at base conditions**

In this case, first the volume at metering conditions is converted into a volume at base conditions using one of the appropriate types of conversion (see above).

Then the mass  $M$  is obtained by the relationship:

$$M = V_b \times \rho_b$$

Where:

$V_b$ : volume at base conditions

$\rho_b$ : density at base conditions

$\rho_b$  is provided in ISO 6976 [12].

## **7.3.3 Associated measuring instruments**

In principle, the characteristic quantities of the measured gas used for the conversion shall be measured by means of associated measuring instruments.

However, depending on national regulations, it is permitted that some of those quantities are not measured at the measuring system location or that the associated measuring instruments are not subjected to a control when it can be demonstrated that the mpe requirements on the converted value are fulfilled. This demonstration is part of documented provisions.

### **7.3.3.1 Temperature sensor**

The temperature sensor shall be installed in order to ensure that the measured temperature is the temperature at metering conditions. It shall be possible to verify on site the measured temperature. For



this purpose, an additional independent temperature tapping shall be located at a short distance from the verified temperature sensor.

#### **7.3.3.2 Pressure transducer**

The pressure transducer shall be connected to the metering pressure tap of the meter.

To avoid errors due to variations in atmospheric pressure, the absolute pressure shall be determined.

When a gauge pressure transducer is used, it shall be possible to preset the value of the average atmospheric pressure. This value shall be calculated taking into account the altitude of the installation site.

It shall be designed so that the pressure measurement can be verified using an additional appropriate pressure measurement means (tap or T connection) at the pressure measurement point.

#### **7.3.3.3 Non standard measuring points**

The associated measuring instruments for which there is no standard tapping point shall be installed close to the meter in order to determine the quantities concerned with sufficient accuracy.

Provided that this is accomplished satisfactorily, measuring instruments may be used to produce conversions and corrections for meters.

These instruments shall not affect the correct functioning of the meter(s).

The deviation in indication due to the locations of the measuring points shall not exceed 20 % of the maximum permissible error for the conversion. Subject to fulfillment of this requirement, the same associated measuring instruments may be used for making conversions and corrections for two or more meters.

*Note:* This requirement is checked by calculation.

#### **7.3.4 Installation**

The conversion device shall be installed in a manner suitable for its application. The presence of the conversion device shall not affect the metrological integrity of the meter(s) and device(s) to which it is associated.

The conversion device and associated measuring instruments shall operate within their rated operating conditions.

The connections of the associated measuring instruments shall be in accordance with the manufacturer's requirements and type approval certificates.

### **7.4 Determination of energy**

#### **7.4.1 Time interval for determination of CV**

7.4.1.1 In principle, the energy to be determined should be the sum of the instantaneous energies delivered. However, in practice this is not possible and it is acceptable not to associate the instantaneous calorific value to the instantaneous corresponding volume at base conditions or mass if:

- a representative CV is determined at time intervals greater than or equal to the minimum time interval laid down in Table 4;
- this representative CV is based on individual CV measurements at time intervals smaller than or equal to the maximum acceptable value laid down in Table 4;

- the representative CV is associated with the quantity measured during the time interval the representative CV is determined;
- the stability of the CV during the time interval of determination of the representative CV is considered as a component of uncertainty.

In other words this leads to a conventional true value resulting from the multiplication of the measured quantity during a period of time at least equal to the minimum time interval by the representative CV corresponding to this duration. Moreover, with the exception of specific identified cases or national practice, it is not necessary to take into consideration the variation of consumption during this period.

The National Authority may impose a maximum time interval for the determination of the representative CV.

**Table 4 Time interval for measuring the CV and determining the representative calorific value**

Accuracy class	A	B	C
Maximum acceptable time interval for individual CV measurements	15 min and depending on CV stability	1 hour	1 hour
Minimum time interval for representative CV determinations	Suitable for the application	1 day	1 day

*Note:* These values apply whatever sampling or measuring method is used.

7.4.1.2 In general, the accuracy of the measurement of energy is verified using a modular approach and the notion of minimum specified energy deviation is meaningless in this case. In the case of the direct verification of energy, as laid down in 6.2, the magnitude of the maximum permissible error is never smaller than the minimum specified energy deviation. For this purpose the minimum measured quantity for energy  $MMQ_e$  is:

$$MMQ_e = Q_{\min} \times t \times H_s$$

Where:

$Q_{\min}$ : minimum flowrate of the measuring system for the volume at base conditions or mass

$t$ : the greater of the following two values:

- effective time interval between determining representative calorific values for the transaction;
- 1 h.

$H_s$ : nominal (mean) measurable calorific value specified by the gas supplier.

## 7.4.2 Determination of the error on energy

### 7.4.2.1 Error of the CVDD

To calculate the error on the CV it is possible to use the actual measurement errors of the CVDD but in general the errors of the CVDD can not be ascertained for each condition of use. Instead of this it is easier to consider the mpes applicable to the CVDD. It is considered that a CVDD fulfilling all the requirements in 6.4 has measurement errors smaller than or equal to the mpes which are applicable to it.

These mpes, hereafter noted  $mpe_{CVDD}$ , are used as the relevant component to calculate the error on the CV.

For the combination of components and as far as necessary, these mpes may be reduced to a resulting “standard uncertainty”,  $u_{CVDD}$ , dividing by the appropriate coverage factor (see 7.4.2.6).

### 7.4.2.2 Uncertainty on the time determination

The provision in 7.4.1 has to be fulfilled and by convention the expanded uncertainty on the time determination is assumed to be nil provided the sampling transit and the delay for gas analysis are negligible or can be corrected for, without significant uncertainty.

When this is not the case, this component is evaluated according to the relevant documented provisions. At the level of this Recommendation it is not possible to state more provisions on this and the validation of the evaluation of this component is the responsibility of the Authority.

For the combination of components and as far as necessary, this expanded uncertainty may be reduced to a resulting standard uncertainty,  $u_T$ , dividing by the appropriate coverage factor (see 7.4.2.6).

### 7.4.2.3 Uncertainty on the stability of the CV

During the time interval over which the representative CV is determined, the stability of the instantaneous CV leads to an uncertainty component,  $U_C$ .

This component is evaluated according to the relevant documented provisions. At the level of this Recommendation it is not possible to state more provisions on this and the validation of the evaluation of this component is of the responsibility of the Authority. Annex C provides examples.

For the combination of components and as far as necessary, this expanded uncertainty may be reduced to a resulting standard uncertainty,  $u_C$ , when dividing by the appropriate coverage factor (see 7.4.2.6).

### 7.4.2.4 Uncertainty on location

When the CV is not determined locally, the corresponding expanded uncertainty,  $U_L$ , is evaluated according to the relevant documented provisions. This component may be due to two main causes: different origins of gases and the transit delay of the gas between the measuring points for the metered quantity and for the CV. At the level of this Recommendation it is not possible to state more provisions on this and the validation of the evaluation of this component is of the responsibility of the Authority. Annex C provides examples.

For the combination of components and as far as necessary, this expanded uncertainty may be reduced to a resulting standard uncertainty,  $u_L$ , dividing by the appropriate coverage factor (see 7.4.2.6).

### 7.4.2.5 Other uncertainties

Without any particular reason, the value of this component is nil. However, the Authority may decide that this is not the case for instance when:

- the configuration of the measuring system is complex and it is necessary to determine standard uncertainties according to type A as laid down in the GUM;
- the gas consumption has been identified as non constant (in a specific contract for instance) and likely to have a significant effect on the final result;
- the level of confidence on the traceability of the CV is not sufficient in the case of non secured communications;
- there are possible effects of interference components on the CV measurements as indicated in 6.4.9.

In this case, the corresponding expanded uncertainty,  $U_o$ , is evaluated according to the relevant documented provisions and, if relevant, the type approval certificate of the CVDD. At the level of this Recommendation it is not possible to state more provisions on this and the validation of the evaluation of this component is of the responsibility of the Authority.

For the combination of components and as far as necessary, this expanded uncertainty may be reduced to a resulting standard uncertainty,  $u_o$ , dividing by the appropriate coverage factor (see 7.4.2.6).

#### 7.4.2.6 Combination of components

Without any particular reason, the conventional coverage factor for determining any of the above corresponding standard uncertainties (from the expanded uncertainty) is 2. This figure is also used when determining the combined error on the CV,  $E_{CV}$ , after the corresponding standard uncertainty has been calculated.

##### 7.4.2.6.1 Simple case

The following is applicable to simple cases such as only one local CVDD, but also to complex situations provided certain assumptions are made. The examples provided in Annex C should cover many situations.

When all the coverage factors are equal to 2 this combined error is provided by one of the two following formulas:

$$E_{CV} = \sqrt{MPE^2_{CVDD} + U^2_T + U^2_C + U^2_L + U^2_O}$$

$$E_{CV} = 2\sqrt{u^2_{CVDD} + u^2_T + u^2_C + u^2_L + u^2_O}$$

Where:

$$u_{CVDD} = mpe_{CVDD}/2 \text{ and } u_i = U_i/2 \text{ (} i = T, C, L, O \text{)}$$

When all the coverage factors may not be considered equal to 2 or when an uncertainty component is directly calculated as an experimental standard deviation, it is appropriate to use the second formula.

$E_{CV}$  is the error on determination on the CV and, as already mentioned and because the calculation errors are very small, is also the error on converting into energy.

##### 7.4.2.6.2 Complex case

In a complex case, it would be necessary to calculate the combined uncertainty according to the GUM, taking into consideration either elementary standard uncertainties as laid down above and/or any appropriate standard uncertainty components evaluated according to documented provisions.

The error on CV determination is twice this combined uncertainty.

### 7.4.2.7 Error of the energy measuring system

When the performances are evaluated according to a modular approach (general case), the error of the measuring system is meaningless as each module fulfils the requirements applicable to it, and taking into account that the global mpes are calculated on the basis of the mpes applicable to the modules.

## 7.5 Marking

7.5.1 Each measuring system, metering module, device or associated measuring instrument, which has been the subject of a type approval, shall bear, legibly and indelibly, either on the indicating device or on a special identification plate, the following indications, as far as relevant:

- a) type approval mark;
- b) manufacturer's identification mark or trademark;
- c) name chosen by the manufacturer (not compulsory);
- d) serial number and manufacturing year; and, if applicable
- e) minimum flowrate,  $Q_{\min}$ ;
- f) maximum flowrate,  $Q_{\max}$ ;
- g) maximum gas pressure,  $P_{\max}$ ;
- h) minimum gas pressure,  $P_{\min}$ ;
- i) maximum gas temperature,  $T_{\max}$ ;
- j) minimum gas temperature,  $T_{\min}$ ;
- k) accuracy class;
- l) nature of the measured gas(es);
- m) minimum calorific value;
- n) maximum calorific value;
- o) climatic and mechanical class, I or O as defined in Annex A;
- p) appropriate information related to the determination of the compressibility factor.

If several meters are operating in one single system, using common elements, the indications prescribed for each part (element) of the system may be gathered on one single plate.

The indications, inscriptions or diagrams required by this Recommendation or by the type approval certificate, shall be written legibly either on the indicating device or close to it.

7.5.2 The measuring system designer shall ensure that markings identified on the indicating device of any meter which is part of the measuring system shall not contravene those on the identification plate of the measuring system (for example the range  $Q_{\min}$  to  $Q_{\max}$  indicated for the meter may not be greater than the corresponding range for the metering module).

## 7.6 Sealing

### 7.6.1 General

Sealing is preferably carried out by means of lead seals. However, other types of sealing are permitted on fragile instruments or when these seals provide sufficient integrity (electronic seals for instance).

Seals shall, in all cases, be easily accessible.

Sealing devices shall be provided on all parts of the measuring systems that cannot materially be protected otherwise against action likely to influence the measuring accuracy.

Sealing devices should prevent the parameters (among others, correction and conversion parameters) used for determining the measurement results from being altered when these parameters are not managed according to documented provisions or a quality assurance system providing traceability of modifications.

A stamping plate, the purpose of which is to receive the control marks, shall be sealed or shall be permanently fixed on the measuring system. This stamping plate may be combined with the identification plate of the measuring system.

### **7.6.2 Electronic sealing devices**

7.6.2.1 When access to parameters that participate in the determination of the results of measurement needs to be protected but is not protected by mechanical seals, the protection shall fulfill the following provisions:

- a) Access shall only be allowed to authorized people, for example by means of a code (keyword) or special device (hard key, etc.); the code shall be changeable. However the National Authority may consider that a code is not sufficient;
- b) It shall be possible to memorize all interventions between two verifications. The record shall include the date and a characteristic element identifying the authorized person making the intervention (see a) above). The traceability of interventions shall be assured for at least two years; if deletion of a previous intervention must occur to permit a new record, the oldest record shall be deleted.

7.6.2.2 For measuring systems with parts which may be disconnected one from another by the user and which are interchangeable, the following provisions shall be fulfilled:

- a) It shall not be possible to access parameters that participate in the determination of results of measurements through disconnected points unless the provisions in 7.6.2.1 are fulfilled;
- b) Interposing any device which may influence the accuracy shall be prevented by means of electronic and data processing securities or, if not possible, by mechanical means.

7.6.2.3 For measuring systems with parts which may be disconnected one from another by the user and which are not interchangeable, the provisions in 7.6.2.2 apply. Moreover, these measuring systems shall be provided with devices which do not allow them to operate if the various parts are not connected according to the manufacturer's configuration.

*Note:* Disconnections which are not allowed to be performed by the user may be prevented, for example by means of a device that prevents any measurement from being carried out after disconnecting and reconnecting.

## **8 Technical requirements for meters, metering modules and ancillary devices**

### **8.1 Meters and metering modules**

#### **8.1.1 Adjustment device**

Meters and metering modules may be provided with an adjustment device which permits modification of the ratio between the indicated volume and the actual quantity passing through the system, by a simple operation.

When this adjustment device modifies this ratio in a discontinuous manner, the consecutive values of the ratio shall not differ by more than 0.001 for classes A and B or 0.002 for class C.

After the determination of the errors of indication, the adjustment shall be made so that the weighted mean error (*WME*) is as close to zero as the adjustment device permits. The *WME* shall be calculated at nominal operating conditions.

Adjustment by means of a by-pass of the meter (s) is prohibited.

## 8.1.2 Correction device

Metering modules may be fitted with correction devices; such devices are always considered as an integral part of the metering module.

The maximum permissible errors defined in Table 2 are applicable to the corrected quantity (at metering conditions).

The purpose of a correction device is to reduce the errors as close to zero as possible.

All the parameters which are not measured but which are necessary for correcting shall be contained in the calculator before any measurement operation is carried out. The type approval certificate shall prescribe the conditions for checking parameters that are necessary for correctness at the time of verification of the correction device.

The correction device shall not allow the correction of a pre-estimated drift in relation to time or volume, for example.

When using a correction device one shall ensure that the error curve to be used is relevant to the actual operating conditions and that the correction device is able to correct all deviations recorded when calibrating the metering module to which it is connected.

The error curve shall be corrected by a correction function  $f(q)$  such that for each operating point the corrected quantity shall equal the indicated quantity of the meters times the correction function  $f(q)$ .

The parameters that determine the correction function  $f(q)$  can be derived from the following:

- from a table of deviations for all the different flowrates noted via the calibration (for example correction by linear interpolation between all the calibration points); or
- from the coefficients of a polynomial having an appropriate degree, and obtained by smoothing of all points noted on calibration (smoothing through the method of least squares, cf. ISO/TR 7066-1 [35] and ISO 7066-2 [36]); or
- by any other method to be specified by the manufacturer.

In any case, the choice of the parameters of the correction function  $f(q)$  shall ensure that at all points, the error curve is definite, continuous and derivable for flowrates between  $Q_{\min}$  and  $Q_{\max}$ .

The correction shall be only authorized between the different calibration points (no extrapolation is allowed). As a consequence, there never can be a correction below  $Q_{\min}$  and above  $Q_{\max}$ .

The manufacturer has to demonstrate that the time reaction of a correction device is consistent with the expected accuracy in the event of quick variations in flowrates.

## 8.2 Indicating device

### 8.2.1 General provisions

8.2.1.1 Reading of the indications shall be precise, easy and unambiguous. If the device comprises several elements, it shall be arranged such that the reading of the measured quantity can be made by simple juxtaposition of the indications of the different elements.

The decimal sign shall appear distinctly.

Indications of principal measurands shall be expressed with eight significant digits.

8.2.1.2 The scale interval of indication shall be in the form  $1 \times 10^n$ ,  $2 \times 10^n$  or  $5 \times 10^n$  in authorized units of the measured quantity, where  $n$  is a positive or negative whole number, or zero.

8.2.1.3 For metered quantities, the minimum specified quantity deviation as defined in T.2.12 shall be equal to or greater than the following value:

- for continuous indicating devices, the measured quantity corresponding to 2 mm on the scale or to one-fifth (1/5) of the scale interval (of the first element for mechanical indicating devices), whichever is greater, and;
- for discontinuous indicating devices, the measured quantity corresponding to two scale intervals.

## **8.2.2 Mechanical indicating device of meters**

When the graduation of an element is entirely visible, the value of one revolution of that element shall be in the form  $10^n$  authorized units of volume, mass or energy; this rule, however, does not apply to the element corresponding to the maximum range of the indicating device.

On an indicating device having several elements, the value of each revolution of an element whose graduation is entirely visible must correspond to the scale interval of the following element.

An element of the indicating device may have continuous or discontinuous movement, but when elements other than the first have only part of their scales visible through the windows, these elements shall have discontinuous movement.

The advance by one figure of any element having discontinuous movement shall occur and be completed when the preceding element passes from 9 to 0.

When the first element has only a part of its scale visible through a window and has a continuous movement, the dimension of that window shall be at least equal to 1.5 times the distance between two consecutive graduated scale marks.

All scale marks shall have the same width, constant along the line and not exceeding one quarter of the scale spacing. The apparent scale spacing shall be equal to or greater than 2 mm. The apparent height of the figures shall be equal to or greater than 4 mm, unless otherwise specified in the requirements for particular measuring systems.

## **8.2.3 Electronic indicating device**

The minimum height of the figures shall be 4 mm and the minimum width shall be 2.4 mm.

It shall be possible to read the displayed values clearly and correctly, within an angle of  $55^\circ$  from normal to the window, within the ambient specified temperature range.

When all the digits of the indicating device are not used, every digit at the left of the indicating device that is not used shall indicate zero.

If the display is non-permanent, the indication time shall be at least 10 s.

Moreover, where the display is sequential and automatic, the energy or when not available the volume at base conditions or the mass shall be displayed at intervals no longer than 15 s. Each quantity shall be displayed for at least 5 s.

## **8.3 Printing device**

### **8.3.1 Printing scale**

The printed scale interval shall be in the form of  $1 \times 10^n$ ,  $2 \times 10^n$  or  $5 \times 10^n$  authorized units of quantity, n being a positive or negative whole number, or zero.

The printing scale shall not be smaller than the smallest scale interval of the indicating device.



### **8.3.2 Printed quantity**

When a printing device is provided, the measurement result, the measurement unit used or its symbol and the decimal sign if any, shall be printed.

### **8.3.3 Identification parameters**

The printing device may also print information identifying the measurement sequence such as: sequence, number, date, identification of the meter, etc.

If the printing device is connected to more than one measuring system, it shall print the identification of the relevant system.

## **8.4 Memory device**

### **8.4.1 Storage unit**

Measuring systems may be fitted with a memory device to store measurement results until their use or to keep a trace of commercial transactions, providing proof in case of dispute. Devices used to read stored information are considered as included in the memory devices.

### **8.4.2 Media reliability and capacity**

The medium on which data are stored must have sufficient permanency to ensure that the data are not corrupted under normal storage conditions. There shall be sufficient memory storage for any particular application.

### **8.4.3 Exhausted storage capacity**

When the storage is full, it is permitted to delete stored data when both the following conditions are met:

- data are deleted in the same order as the recording order and the rules established for the particular application are respected;
- deletion is carried out after a special manual operation.

### **8.4.4 Data storage protection**

Memorization shall be such that it is impossible to modify stored values without breaking the seals or similar actions.

## **8.5 Associated measuring instruments**

### **8.5.1 General**

The associated measuring instruments shall conform to pertinent International Standards and Recommendations. Additionally, those instruments shall exhibit accuracy such that the requirements on accuracy of measuring systems and components in 6.3 are fulfilled.

The instruments used for measuring the temperature, pressure, differential pressure, density and used to determine the calorific value shall display directly and/or record the measured values, or shall be fitted with a transmitter to send signals to separate equipment used to display, record or store the measured quantities. In any case the measuring result shall be accessible.

## **8.5.2 Scale intervals for associated measuring instruments other than CVDD**

The indication scale intervals of the density, pressure and temperature shall not exceed 25 % of the maximum permissible errors for the associated measuring instruments.

## **8.5.3 Scale interval for CVDD**

According to the case the scale interval shall be either 5 kJ/m<sup>3</sup> or 1 Wh/m<sup>3</sup>, or 5 kJ/kg or 1 Wh/kg.

## **8.6 Volume conversion device**

### **8.6.1 General**

8.6.1.1 All the constituent elements of conversion devices shall be constructed of materials having appropriate qualities to resist the various forms of degradation which may occur under normal operating conditions as specified by the manufacturer. Properly installed conversion devices shall also be able to withstand normal external influences. Conversion devices shall, in all circumstances, withstand the overload of pressure and the temperatures for which they are designed, without malfunction.

8.6.1.2 A conversion device shall be designed in such a way that it does not degrade the accuracy of the measurement of the meter with which it is associated.

8.6.1.3 The conversion factor shall be recalculated at intervals not exceeding 30 s.

However, when no signal has been received from the gas meter for over 30 s, the recalculation is not required until a next signal is received.

8.6.1.4 Conversion devices may be fitted with interfaces allowing the connection of supplementary devices. Such connections shall not corrupt the metrological operation of the conversion device.

8.6.1.5 The interconnection cables between the calculator and the transducers are integral parts of the conversion device. The manufacturer shall specify the length and characteristics of the interconnection links where these may affect the safety or accuracy of measurement or the conversion device.

## **8.7 Calculator**

8.7.1 The non measured data necessary for conversions and correction shall be present in the calculator before a measurement is made. It shall be possible to print or display these data from the calculator memory. Any modification to the non measured data shall require breaking of security seals or updating an audit trail.

8.7.2 In case of any calculator halt, it shall maintain in memory the principal measurands and input parameters for example pressure, temperature and alarm indications. The calculator shall maintain the values prevailing at the moment it was halted.

The data shall remain accessible for a minimum of six months. The calculator shall be capable of resuming normal operation as soon as the reason for the halt is removed.

## **8.8 Calorific value determining device**

### **8.8.1 Types of calorific value determining devices**

The calorific value of natural gas can be determined using different techniques which fall into the following categories:

direct measurement, i.e.

- direct combustion,
- catalytic combustion,

indirect measurement, i.e.

- stoichiometric combustion,

inferential determination, i.e.

- correlation with other measured properties,
- composition based calculation.

Depending on certain conditions, online or offline measuring devices may be used.

Online calorific value determining devices have their sampling system directly connected to the gas network.

For offline calorific value determining devices sampling is performed indirectly using for instance gas vessels.

When provided, the sampling system shall not influence other parts of the measuring system and shall also allow representative samples to be taken of the gas having passed the meter.

Guidelines for the design and operation of sampling systems are described in ISO 10715 [38].

### **8.8.2 Adjustment procedures**

The aim of an adjustment procedure is to bring the calorific value determining device into conditions of operation according to its intended use and accuracy.

If applicable (see 6.4.3 and 8.8.3), the manufacturer shall provide the appropriate adjustment procedure.

In particular, adjustment procedures shall be established taking into account the following factors:

- the number of calibration gases to cover the operational range;
- the adjustment interval (i.e. the interval between adjustments will be a function of the stability and the repeatability of the measuring instrument);
- the duration of the adjustment test and the number of adjustments.

These calibration gases shall be prepared and certified according to Annex E.

The measurement uncertainty of calibration gases shall fulfill the requirement in 10.

For chromatographic devices, the gas shall contain the essential components.

### **8.8.3 Adjustment range**

The adjustment range shall be limited in order to prevent excessive corrections. The corresponding limits shall be suitable for the intended use. Outside the range the CVDD shall no longer operate and shall generate a warning message.

### **8.8.4 Metrological policy concerning calorific value measurements**

According to their policy, National Authorities may impose, in particular, one or more of the following provisions:

- periodicity of routine verifications of CVDD by the user;
- periodicity of routine adjustments of CVDD by the user;
- prohibiting the access to adjustment devices of CVDD to the user;
- the presence of automatic internal adjustments means for CVDD;
- the type(s) of CVDDs to be used.

### **8.8.5 Storage of data**

The CVDD shall be accompanied by an ancillary device allowing the storage of appropriate data in order to determine the representative calorific values.

### **8.9 Energy conversion device**

Any relevant provision in 8.6 applies by analogy to energy conversion devices.

## **9 Technical requirements for electronic devices**

### **9.1 General requirements**

9.1.1 Electronic measuring systems and devices shall be designed and manufactured so that they continue to operate as designed and so that their errors do not exceed the relevant maximum permissible errors under rated operating conditions and which are defined in 6.2 and 6.3.

*Note:* For manufactured measuring instruments, national or regional regulations may prescribe that continuing to operate under rated operating conditions is the responsibility of the manufacturer. This may allow the manufacturer to replace purely digital elements which cannot influence the characteristics and/or the performance of the measuring instruments by other equivalent elements without having to demonstrate that the measuring instrument continues to operate as designed.

9.1.2 Electronic measuring systems and devices shall be designed and manufactured in such a way that no significant faults occur when they are exposed to the disturbances specified in Annex A.

9.1.3 The requirements in 9.1.1 and 9.1.2 shall be met durably. For this purpose, electronic measuring systems shall be provided with the checking facilities specified in 9.3. However, this requirement is not applicable to the internal securing (internal checking facilities, etc.) of gas meters designed in conformity with an OIML International Recommendation.

9.1.4 A type of a measuring system or device is presumed to comply with the requirements in 9.1.1 to 9.1.3 if it passes the examination and tests specified in (10.2.11.1 and 10.2.11.2).

9.1.5 Measuring systems shall permit the retrieval of the information relating to the measured quantity contained within the instrument before a significant fault occurred and was detected by the checking facilities.

9.1.6 Electrical connections should be clearly identified. If they are intended for use with separately approved peripheral equipment, they shall conform to the electrical interfacing standard used by the peripheral equipment to transmit their information. Compatibility will not only include the electrical levels and signal shape but also the communication protocol in use.

*Note:* This paragraph is only applicable to the metrological aspects of the liaison.

### **9.2 Power supply device**

#### **9.2.1 External power supply (AC or DC)**

In case of failure of the external power supply and, if provided, before failure of the emergency power supply, the latest measured parameters and alarms shall be recorded.

### 9.2.2 Battery powered device

The manufacturer shall specify the minimal duration of functioning without replacing the battery under the following conditions:

- maximum allowable frequency input from the meter;
- minimum ambient temperature;
- $P_{\max}$  and  $T_{\min}$ .

The instrument shall indicate that the battery or any form of electrical supply has to be recharged or replaced before 90 % of the life or of the estimated life of the battery has been exceeded.

The replacement of the battery shall be possible without breaking any metrological seals of the device. Separate seals may be provided for the battery enclosure.

During the battery exchange the following information has to be retained (when applicable):

- the energy;
- the volume at base conditions;
- the mass;
- the volume at metering conditions;
- the corrected volume;
- the calorific value;
- the alarms indications;
- the event logs;
- the entered data specified in 8.7.1.

The type of battery(ies) specified by the manufacturer shall be used.

## 9.3 Checking facilities

### 9.3.1 Action of checking facilities

The detection by the checking facilities of significant faults shall result in the following actions, according to type:

#### 9.3.1.1 Checking facilities of type N

A visible or audible alarm for the attention of the operator.

#### 9.3.1.2 Checking facilities of types I or P

- automatic correction of the fault; or
- stopping only the faulty device when the measuring system without that device continues to comply with the regulations; or
- a visible or audible alarm for the operator. This alarm shall operate until the cause of the alarm is suppressed. In addition, when the measuring system transmits data to ancillary devices, the transmission shall be accompanied by a message indicating the presence of a fault.

*Notes:* 1 The third action is not applicable for the disturbances specified in Annex A, as no significant fault is allowed during the tests.

2 In addition, the metering system may be provided with devices to estimate the amount of gas having passed through the installation during the occurrence of the fault. The result of this estimate shall not be capable of being misinterpreted for a valid indication.

However, a visible or audible alarm is not sufficient unless the alarm is transferred to a remote station. The transmission of the alarm need not be secured provided its occurrence, if any, remains accessible until the settlement of the transaction.

### **9.3.2 Checking facilities for the flow measuring device**

The objective of these checking facilities is to verify the presence of the flow measuring device, its correct operation and the correctness of data transmission.

9.3.2.1 When the signals produced by the flow measuring device are made up of pulses, each being representative of an elementary volume, the checking facility shall operate at least every two pulses. However, if the period between two consecutive pulses is smaller than 30 s, it is not required for the checking facility to operate more than once a minute.

The flow measuring device may generate more than one primary signal from different origins (different phases and/or frequencies). In this case, a checking facility of type I may also be used to compare the different signals.

When the signals produced by the flow measuring device are made up of pulses, each being representative of an elementary volume, the security Level B specified in ISO 6551 [37] shall at least be adhered to, except for equipment with a cable length at most 3 m, for which Level C may be applied.

It shall be possible to demonstrate the operation of this checking facility during type approval either:

- by disconnecting the measuring transducer; or
- by removing one of the impulse sources of the sensor; or
- by removing the power supply of the measuring transducer.

This checking shall be also possible at initial verification unless the presence and the efficiency of the checking facility are ensured by the conformity to type.

9.3.2.2 In case of any other technological choice, the checking facility shall assure equivalent levels of security.

### **9.3.3 Checking facilities for the calculator**

The following requirements apply to any part of the system that performs calculations, in particular the calculator, the calorific value determining devices and, if applicable, to other associated measuring instruments.

The object of these checking facilities is to check whether the calculator system functions correctly and to ensure the validity of the calculations made.

No special means are required for indicating that these checking facilities function correctly.

9.3.3.1 The checking of the functioning of the calculation system shall be of types P or I. In the latter case, the checking shall occur at least every five minutes.

The objective of the checking is to verify that:

- a) the values of all permanently stored instructions and data are correct, by such means as:
- summing up all instructions and data codes and comparing the sum with a fixed value;
  - line and column parity bits (LRC and VRC);
  - cyclic redundancy check (CRC 16);
  - double independent storage of data;
  - storage of data in “safe coding”, for example protected by checksum, line and column parity bits;

b) all procedures of internal transfer and storage of data relevant to the measurement result are performed correctly, by such means as:

- read-write routine;
- conversion and reconversion of codes;
- use of “safe coding” (check sum, parity bit);
- double storage.

9.3.3.2 The checking of the validity of calculations shall be of type P. This consists in checking the correct value of all data related to the measurement whenever these data are internally stored or transmitted from/to peripheral equipment through an interface; this checking may be carried out by such means as parity bit, check sum or double storage.

In addition, the calculation system shall be provided with a means of controlling the continuity of the calculation program.

#### **9.3.4 Checking facility for the indicating device**

The objective of this checking facility is to verify that the primary indications are displayed and that they correspond to the data provided by the calculator. In addition, it aims at verifying the presence of the indicating devices, when they are removable.

The control may be performed according to either the first approach in 9.3.4.2 or the second approach in 9.3.4.3.

9.3.4.1 Unless the presence and the efficiency of the checking facility is ensured by the conformity to type, it shall be possible during verifications to determine that the checking facility of the indicating device is working, either:

- by disconnecting all or part of the indicating device; or by
- an action which simulates a failure in the display, such as using a test button.

##### **9.3.4.2 First approach**

This checking consists in checking the complete indicating device.

The checking facility of the indicating device is of type P. However, it may be of type I if a primary indication is provided by another device.

Means may include, for example:

- for indicating devices using incandescent filaments or LEDES, measuring the current in the filaments;
- for indicating devices using fluorescent tubes, measuring the grid voltage; or
- for indicating devices using multiplexed liquid crystals, output checking of the control voltage of segment lines and of common electrodes, so as to detect any disconnection or short circuit between control circuits.

##### **9.3.4.3 Second approach**

First, the checking facility for the indicating device shall include type I or type P checking of the electronic circuits used for the indicating device (except the driving circuits of the display itself). The type I may be used if a primary indication is provided by another device.

Second, the checking facility for the indicating device shall include a type N checking for the display.

This control shall have the following characteristics:

- display of all elements (“eight” tests);
- extinction of all elements (“white”);
- display of the “zeros”; or
- any other sequence of automatic tests showing all possible states for each element of the display.

### **9.3.5 Checking facilities for ancillary devices**

An ancillary device (repeating device, printing device, memory device, etc.) with primary indications shall include a checking facility of type I or P. The object of this checking facility is to verify the presence of the ancillary device, when it is a necessary device, and to verify the correct transmission of data between the calculator and the ancillary device.

In particular, the checking of a printing device aims at ensuring that the printing controls correspond to the data transmitted by the calculator. At least the following shall be checked:

- presence of paper;
- the electronic control circuits (except the driving circuits of the printing mechanism itself).

It shall be possible during type approval to check that the checking facility of the printing device is functioning by an action simulating a printing fault, such as using a test button. This checking shall also be possible at initial verification, unless the presence and the efficiency of the checking facility are ensured by the conformity to type.

In the case of a memory device the correct memorizing shall be checked.

Where the action of the checking facility is a warning, this shall be given on or by the ancillary device concerned.

### **9.3.6 Checking facilities for the associated measuring instruments**

Associated measuring instruments shall include a checking facility of type P. The aim of this checking facility is to ensure that the signal given by these associated instruments is inside a pre-determined measuring range.

*Note:* This provision is not linked with the value of the significant fault but is provided in order to provide durability.

As long as a defective operation is detected by the checking facility, any further increase of the converted quantities shall not be permitted. However, it is allowed to calculate separately an informative converted value when the signal given by the associated instruments is outside a pre-determined measuring range.

The volume at metering conditions and the corrected volume (if included) shall always increase.

In cases where associated measuring instruments perform calculations, in particular calorific value determining devices, provisions in 9.3.3 apply in addition.

### **9.3.7 Checking facility for the control of the flow control equipment**

The provisions in 9.3.6 apply to the control of flow control equipment.



## 10 Metrological control

### 10.1 General

10.1.1 A measuring system shall always be examined on the site of use. In any case the measuring system in use has to fulfill or has to be assumed to fulfill the applicable requirements.

This means that tests should be performed on site too. However, in particular in the case of a meter or a metering module, tests on site are in general difficult or impossible to perform. For this reason, the National Authority may decide that tests are performed in the laboratory. This Recommendation has been established (in particular Annex B) in order to provide confidence in measurements on site, even if some tests are not performed on site.

Also it should be noted that according to current practices, the verification of energy may only be performed on the basis of separate verifications of modules. This modular approach leads to verification in a laboratory or on site according to what is most appropriate for each module (see Annex C):

- the meter, taking into account the conditions of its installation in the system, that is the metering module;
- if applicable the device converting the quantity at metering conditions into a volume at base conditions or a mass;
- if applicable the device used to determine the calorific value;
- if applicable the device converting the volume at base conditions or the mass into energy.

10.1.2 When a test is conducted, the expanded uncertainty,  $U$  (for  $k=2$ ) for the determination of errors on indications of volume or mass, shall be less than one-third of the maximum permissible error applicable at type approval, at initial and at subsequent verifications. However, the uncertainty never needs to be less than 0.3 %.

*Note:* This last figure leads to an uncertainty/mpe ratio which can be considered as large in legal metrology for type approval but which corresponds to the state of the art for calibration in gas metering and to the needs of industry, even if this may lead to a false idea of actual accuracy taking into consideration uncertainties. Moreover:

- often the standard used for adjustment is the one used for verification;
- mpes apply to errors after adjustment using *WME* or correction.

This limits the risk of undue refusal of correct instruments.

For the determination of errors on indications of calorific value the expanded uncertainty shall be less than one-third of the maximum permissible error applicable at each stage of the metrological control.

The estimation of expanded uncertainty is made according to the GUM [7].

As far as necessary, the working standards and their use will be the subject of specific International Recommendations.

### 10.2 Type approval

#### 10.2.1 General

Measuring systems subject to legal metrological control shall be subject to type approval.

The type approval of a measuring system is a general concept because a system may involve components located very far away from the meter, which may be shared with other systems. It may also involve documented provisions. This is true in particular for Class C measuring systems. In any case, type (or unit) approvals for complete systems shall be granted after it has been verified that the requirements specified in this Recommendation are fulfilled for the system. However, this shows that

the concept of “measuring system” may be very abstract and in some cases the type approval certificate may be replaced by any suitable document providing the authorization required by the law.

Moreover, the elements of a measuring system, and more particularly those mentioned in the list below, may be the subject of a separate approval (either according to this Recommendation or to specific Recommendations or to the approval certificate of the measuring system):

- metering module;
- electronic calculator associated with the indicating device;
- indicating device;
- conversion device;
- pressure associated measuring instrument;
- temperature associated measuring instrument;
- density associated measuring instrument; and
- calorific value determining device.

However, it is considered that type approval of a temperature sensor conforming to IEC 60751/A2 [33] is not necessary.

As far as possible information on compatibility of a device with other devices is provided in the type approval certificate.

### **10.2.2 Documentation**

10.2.2.1 The application for type approval of a measuring system or a constituent element of a measuring system shall be accompanied by the following documents:

- a description of the technical features and the operating principle;
- a drawing or a picture;
- process instrumentation diagrams;
- a parts list (with the description of these parts' constituent materials when they are relevant at metrological level);
- a diagram for assembly (with identification of the constituent elements);
- for the measuring system, the references to the type approval certificates of the constituent elements, if any;
- for a measuring module and a meter equipped with a correction device, a description of the means used to determine the correction parameters;
- a diagram showing the locations of seals and verification marks;
- a plan of the prescribed inscriptions;
- for a CVDD, adjustment procedures;
- documented provisions; and
- any document or proof supporting the assumption that the design and construction of the measuring system meet the requirements of this Recommendation.

10.2.2.2 In the case of an electronic measuring system, the application shall also include:

- when provided, a description of the electronic seals;
- a functional description of the various electronic devices;
- a flow chart of the software, explaining how the electronic devices work.

10.2.2.3 The applicant shall provide the organization responsible for the examination with an instrument representing the final model or access to the complete installation.

### **10.2.3 Type approval certificate**

The type approval certificate shall bear the following information:

- name and address of the beneficiary of the type approval certificate;

- name and address of the manufacturer, if he is not the beneficiary;
- type and/or trade name;
- main metrological and technical features;
- type approval mark;
- period or limit of validity;
- rated operating conditions;
- specific conditions for initial and subsequent verifications if applicable;
- information on location of type approval marks, initial verification marks and sealing (for example picture or drawings);
- list of the documents accompanying the type approval certificate;
- special remarks.

When applicable, the version of the metrological part (the complete part if there is no specific metrological part) of the evaluated software shall be indicated in the type approval certificate or in its annexes.

#### **10.2.4 Modification of an approved type**

The beneficiary of the type approval shall inform the body that granted the approval of any modification or any addition to an approved type.

Modifications or additions shall be the subject of a supplementary approval when they influence or might influence the measurement results or the metrological characteristics.

The organization in charge of the approval of the modified type has to consider the nature of the modification and the initial folder when deciding whether and to which extent the applicable examinations and tests have to be performed on the modified type. A new or supplementary type approval shall be issued whenever the modified measuring system or device no longer fulfils the provisions of the initial type approval certificate.

#### **10.2.5 Type approval of a measuring system**

Type approval of a measuring system comprises checking whether the constituent elements of this system satisfy the applicable requirements (even if type approval is not requested for the constituent elements) and that these constituent elements are compatible with one another. For instance the performance tests on accuracy of a calculator have to be performed in any case when a device includes a calculator.

Tests for carrying out the type approval of a measuring system shall therefore be determined on the basis of the type approvals (or evaluation) already granted for the constituent elements of the system.

When none of the constituent elements has been subject to separate type approval, all the applicable tests provided for in 10.2.6 to 10.2.12 shall be performed on the whole measuring system. On the contrary, when the various constituent elements are all approved separately, it is possible to replace type approval based on tests by type approval on drawings and design.

It is also appropriate to reduce the type evaluation program when the measuring system includes constituent elements identical to those which equip another measuring system that has already been approved, and when the operating conditions of these elements are identical.

*Note:* It is advisable that constituent elements be subject to separate type approval when they are intended to equip several types of measuring systems. This is particularly advisable when the various measuring systems have different manufacturers and when the bodies in charge of type approval are different.

When the measuring system involves documented provisions, appropriate analysis and investigations are implemented.

### 10.2.6 Type approval of a metering module

A metering module shall fulfill all requirements applicable to the hydraulic part of the measuring system including the meter in particular, laid down in this Recommendation. In particular, the liaison between a meter and an electronic device shall be secured with checking facilities.

The philosophy of the modular approach specified in 10.1.1 is applicable.

The following examinations and tests shall be carried out on the metering module.

The metering module shall be fitted with all ancillary devices likely to influence the accuracy of the metering module. The flow measuring device may also be tested without the calculator and the indicating device, provided they have been subject to a separate type approval. If this flow measuring device is intended to be connected to a calculator fitted with a correction device, the correction algorithm as described by the manufacturer must be applied to the output signal of the measuring transducer to determine its errors.

#### 10.2.6.1 Accuracy tests at nominal operating conditions

At nominal operating conditions as declared by the manufacturer, the errors of the metering module shall be determined at a minimum of seven flowrates which are distributed over the measuring range at appropriate intervals (e.g.  $Q_{\min}$ , 5 % of  $Q_{\max}$ , 15 % of  $Q_{\max}$ , 25 % of  $Q_{\max}$ , 40 % of  $Q_{\max}$ , 70 % of  $Q_{\max}$ , 100 % of  $Q_{\max}$ ). At each flowrate the errors shall be determined at least three times, independently and consecutively.

Each individual error shall be recorded in order to calculate the global error of the metering module at metering conditions, taking into account the tests referred to in 10.2.6.2 and laid down in Annex B.

Moreover the results of accuracy tests at nominal operating conditions shall meet the requirement on repeatability in 6.6.

#### 10.2.6.2 Accuracy tests at metering conditions

10.2.6.2.1 Tests laid down in Annex B shall be performed.

10.2.6.2.2 Moreover and when applicable, the results of tests performed according to 10.2.6.1 and 10.2.6.2.1 are taken into account for determining mpes at the first stage of initial verification, according to B.6.1.

10.2.6.2.3 Tests in real situation of use may be necessary according to the technology and the policy of the legal authority. These tests are mandatory for meters of another technology than those considered in Annex B.

10.2.6.2.4 An endurance test should be carried out using the gas the metering module is intended to measure or a gas with similar effects considering endurance. When the metering module is intended to measure two or more gases, the test should be carried out with the gas that provides the most severe conditions. However, any other gas may be used provided that it can be demonstrated that the test is equivalent.

The test may be performed on the meter alone if it can be assumed that other parts of the metering module will not influence the test result.

An accuracy test shall precede the endurance tests.

In principle the duration of the endurance test shall be 2 000 hours in one or several periods not extending over a period of 120/150 days.

The test shall be carried out at a flowrate between  $0.8 Q_{\max}$  and  $Q_{\max}$ .

As far as possible, the metering module is subjected to the endurance tests on a test bench. However, it is accepted that the metering module be temporarily mounted in a measuring system in normal

operation, in which case it is necessary that the nominal operating flowrate of the metering module is more than  $0.8 Q_{\max}$ .

After the endurance test, the metering module is again subject to a new accuracy test. The deviations between the mean value of errors determined before and after the endurance test shall remain within the limits specified in 6.7 without any changes of the adjustment or corrections.

10.2.6.2.5 When the metering module is fitted with electronic components, it is also necessary to perform examinations and tests described in 10.2.11 for electronic devices.

### **10.2.7 Type approval of a calorific value determining device**

In order to verify a CVDD fulfils the applicable requirements, it is subject to the following provisions.

Prior to the tests the CVDD is adjusted according to the manufacturer's procedure.

As far as applicable (see 8.8.3), in the course of tests the CVDD is readjusted according to the adjustment interval and the adjustment procedure specified by the manufacturer. Any adjustment is recorded and shall be mentioned in the test report.

#### 10.2.7.1 Performance tests under reference conditions

As a general rule, tests shall be carried out using a minimum of six test gases of traceable and certified calorific value. The range of calorific values of these test gases should be wider than the required operational range; it would be normal for one test gas calorific value to be slightly lower than the minimum of the operational range and for one to be slightly higher than the maximum value of the operational range. Other gases shall be regularly spaced in the measuring range.

The accuracy of the CVDD shall conform to the requirements in Table 2. However, if this provision is not fulfilled for the calibration gases having values slightly outside the operational range, the corresponding tests may be restarted in order to better suit this range.

#### 10.2.7.2 Performance tests under influence quantities

These tests aim at verifying that the complete CVDD complies with the provisions in 9.1.1 and 9.1.2 with regard to influence quantities.

These tests are specified in Annex A.

##### **a) Performance under the effect of influence factors:**

Tests are performed using at least one gas whose calorific value or composition differs the most from that of the gas(es) used for the adjustment, as far as available.

When submitted to the effect of influence factors as provided for in Annex A, the equipment shall continue to operate correctly and the errors shall not exceed the applicable maximum permissible errors.

##### **b) Performance under the effect of disturbances:**

Tests are performed using one gas within the measuring range.

When submitted to external disturbances as provided for in Annex A, significant faults shall not occur.

#### 10.2.7.3 Repeatability

The tests are carried out using gases of constant calorific value, or constant composition as the case may be, but not necessarily of certified value.

Three gases are used, one close to the lowest calorific value, one close to the highest calorific value and one approximately at the middle of the range. At least five (and normally not more than ten) measurements are performed with each gas.

The three repeatability errors so determined shall fulfill the requirement in 6.4.2.

#### 10.2.7.4 Adjustment interval and drift

The verification of the adjustment interval is made using the same gas at the beginning and the end of the adjustment interval.

The same gases are used as those referred to for repeatability tests.

The drift shall fulfill the requirement in 6.4.3. The tolerance applies to the mean value of three measurements.

#### 10.2.7.5 Influence of the gas composition

The test shall be performed using at least two gases of different compositions having approximately the same calorific value. These gases may be used for the accuracy tests laid down in 10.2.7.1 in particular.

The difference in the calorific values is within 3 % and the variation of mole fractions of the main component has to be higher than 5 %.

Three calorific value measurements are performed with each gas. For each gas the mean value of the three results is calculated.

The difference between the conventional true value for gas 1 and the conventional true value for gas 2 is calculated.

The difference between the mean value for gas 1 and the mean value for gas 2 is calculated.

The algebraic difference between these two differences shall fulfill the requirement in 6.4.4.

Repeat and adapt the procedure if more than two gases are used.

#### 10.2.7.6 Response time

The gases used are the two used for the tests in 10.2.7.1 having the largest different calorific values. One is supplied at the input of the CVDD for at least three measurements in order to obtain stabilized results.

Then the CVDD is immediately supplied with the other gas in order to perform the number of necessary measurements.

If the conclusion could be order dependent the test shall be repeated changing the order of the gases.

The CVDD shall fulfill the requirement in 6.4.5. After the given time, at least three measurements are performed. Each individual measurement shall fulfill the requirement.

#### 10.2.7.7 Influence of gas supply

The influences of supply gas(es) pressure and flowrates are tested using two of the test gases in 10.2.7.1 having the largest different calorific values.

Tests are performed for extreme conditions of supply specified by the manufacturer. When one parameter is tested, the other parameters are maintained at nominal operating conditions.

When submitted to the effect of these influence factors, the equipment shall continue to operate correctly and the errors shall not exceed the applicable maximum permissible errors.

#### 10.2.7.8 Specific tests for calorimeters

##### 10.2.7.8.1 Influence of atmospheric pressure

The influence of atmospheric pressure is tested in conditions laid down in a) in 10.2.7.2.

When submitted to the effect of this influence factor, the equipment shall continue to operate correctly and the errors shall not exceed the applicable maximum permissible errors.

#### 10.2.7.8.2 Installation effects

Concerning air movements there is no test to perform if the manufacturer declares that the calorimeter has to be installed in ambiances without air movements. If the manufacturer specifies other conditions, tests with the gases specified in 10.2.7.7 have to be performed in appropriate conditions.

Corresponding ambient conditions are specified in the type approval certificate.

When submitted to the effect of these influence factors, the equipment shall continue to operate correctly and the errors shall not exceed the applicable maximum permissible errors.

#### 10.2.7.9 Specific provisions for gas chromatographs

For gas chromatographs the tests as described in 10.2.7.1 shall be carried out using at least seven test gases of traceable and certified composition. The concentration range for each component should be wider than the required operational ranges; it would be normal for each component to be tested at one concentration slightly lower than the specified minimum value and at one concentration slightly higher than the specified maximum value except where this concentration is 100 %.

However, if the requirement is not fulfilled for the calibration gases having values slightly outside the operational range, the corresponding tests may be restarted in order to better suit this range.

#### 10.2.7.10 Additional tests for other influences

As far as necessary, additional tests are performed according to the state of the art and provisions in 6.4.9.

### **10.2.8 Type approval of a volume conversion device**

10.2.8.1 There are three ways to verify the conformity of a volume conversion device.

10.2.8.1.1 The first way corresponds to 6.3.3.1 and consists in verifying separately:

- 1 The accuracy of associated measuring instruments (see Table 3-1 in 6.3.3.1.1). Each quantity representative of the gas is varied separately. The tests involve fuel gas or any appropriate substitute method.
- 2 The accuracy on the calculation of each characteristic of the gas (see 6.3.3.1.2 and 10.2.10.2). Each quantity representative of the gas is varied separately.
- 3 The accuracy on the calculation of volume at base conditions or mass (see 6.5 and 10.2.10.2). All combinations of the measured quantities representative of the gas may be tested and, at least combinations of extreme values.
- 4 It is also necessary to perform examinations and tests described in 10.2.11 for electronic devices.

It is possible to limit tests on influence factors to the worse cases of combinations anticipated from tests 1 to 3.

In principle tests on disturbances are performed for one combination of the quantities representative of the gas.

10.2.8.1.2 The second way corresponds to 6.3.3.2 and consists in verifying separately:

- 1 The accuracy of associated measuring instruments (see Table 3-1 in 6.3.3.1.1). Each quantity representative of the gas is varied separately. The tests involve fuel gas or any appropriate substitute method.
- 2 As the values processed by the conversion device are those delivered by the digital associated measuring instruments, the verification of the accuracy on the calculation of each characteristic of the gas is not relevant.

- 3 The accuracy on the calculation of volume at base conditions or mass (see 6.5 and 10.2.10.2). All combinations of the measured quantities representative of the gas may be tested and, at least combinations of extreme values.
- 4 It is also necessary to perform examinations and tests described in 10.2.11 for electronic devices.

It is possible to limit tests on influence factors to the worse cases of combinations anticipated from tests 1 and 3.

In principle, tests on disturbances are performed for one combination of the quantities representative of the gas.

10.2.8.1.3 The third way corresponds to 6.3.3.3 and consists in verifying that the conversion device connected to all its associated measuring instruments complies with the provisions of Table 3-2. For that purpose, the volume at metering conditions that is converted is considered to be without error. The procedure involves the following tests.

### **1 Tests at reference conditions**

All influence factors are at reference conditions and all combinations of the measured quantities representative of the gas may be tested, and at least combinations of extreme values.

In the case of a type of conversion other than a conversion only as a function of temperature, at least 3 gases of different compositions shall be used in order to evaluate the influence of the compressibility factors.

### **2 Tests at rated operating conditions**

a) Conversion device performing conversion only as a function of temperature. Each influence factor is varied separately. The tests are performed for the extreme values of the temperature of the gas and the nominal value.

b) For other conversion devices, each influence factor is varied separately. All combinations of the measured quantities representative of the gas may be tested, and preferably combinations of extreme values. However, it is possible to limit tests on influence factors to the worse cases of combinations anticipated from tests in 1 and/or of types of gas.

### **3 Tests for electronic devices**

It is also necessary to perform examinations and tests on disturbances described in 10.2.11 for electronic devices.

In principle, tests on disturbances are performed for one combination of the quantities representative of the gas.

10.2.8.2 As far as necessary the type approval certificate provides information on the compatibility of the output of the meter and the input of the conversion device and with associated measuring instruments.

## **10.2.9 Type approval of an energy conversion device**

Type approval of an energy conversion device necessitates:

- to verify that the provisions in 10.2.10.1 are fulfilled;
- to perform the examinations and tests described in 10.2.11 for electronic devices;
- to identify the necessary conditions of compatibility applicable to the associated CVDDs or the list of these CVDDs.

*Note:* In general CVDDs are approved separately.

The quantity that is converted is considered to be without error.



### **10.2.10 Type approval for an electronic calculator**

Type approval tests are conducted on the calculator alone, simulating different inputs with appropriate standards.

10.2.10.1 The accuracy tests include all of the tests to ensure the accuracy of the measuring result indications (volume at metering conditions, direct mass or energy).

True values are calculated on the basis of the simulated quantities applied to the calculator's inputs and using standardized methods for the calculations as far as necessary or they exist. The maximum permissible error is as specified in 6.5.

10.2.10.2 When the calculator performs calculations for a volume conversion device, in the case of a modular approach, the tests stated in 10.2.10.1 are carried out for the calculation of volume at base conditions or mass.

In the case of the first modular approach, accuracy tests also include an accuracy test on the measurement of each characteristic quantity of the gas. For this purpose, the error obtained on the indication of each of these characteristic quantities (these indications are mandatory considering 8.5.1) is calculated by considering the conventional true value as provided by the standard connected to the inputs of the calculator and which simulates the corresponding associated measuring instrument. For each of these quantities, the maximum permissible errors are as specified in 6.3.3.1.2.

It is then necessary to perform a test to check the presence and operation of the checking facilities relevant to associated measuring instruments mentioned in 9.3.6.

10.2.10.3 The examinations and tests described in 10.2.11 for electronic devices shall be performed.

### **10.2.11 Type approval for an electronic device**

In addition to the examinations or tests described in the preceding subclauses, an electronic measuring system or an electronic constituent element of this system shall be subject to the following examinations and tests.

*Note:* The work on software of OIML TC 5/SC 2 should be taken into consideration. Nevertheless, since this SC has not yet provided any appropriate documents, National Authorities shall implement appropriate provisions.

#### 10.2.11.1 Design examination

Documents shall be examined to determine whether the design of electronic devices and their checking facilities comply with the requirements of this Recommendation.

The examination includes:

- examining the mode of construction of the electronic sub-systems and components, to verify their appropriateness for their intended use;
- considering the faults that are likely to occur in order to verify that in all considered cases these devices will comply with all requirements in 9.3; and
- verifying the presence and effectiveness of the test device(s) for the checking facilities.

#### 10.2.11.2 Performance tests

These tests aim at verifying that the measuring system or the device complies with the provisions in 9.1.1 and 9.1.2 with regard to influence quantities. These tests are specified in Annex A.

##### a) Performance under the effect of influence factors:

When submitted to the effect of influence factors as provided for in Annex A, the equipment shall continue to operate as designed and the errors shall not exceed the applicable maximum permissible error.

## b) Performance under the effect of disturbances:

When submitted to external disturbances as provided for in Annex A, significant faults shall not occur.

## 10.2.11.3 Equipment under test (EUT)

The electronic devices shall be submitted separately for testing and shall comprise, as far as metering modules are concerned, at least the following devices:

- flow measuring device;
- calculator;
- indicating device;
- power supply; and
- correction device, if any.

This equipment has to be included in a system enabling a representative simulation of the normal operation of the measuring system. For example, an appropriate device may simulate the gas movement.

The peripheral equipment may be tested separately.

CVDDs are tested as a whole.

**10.2.12 Type approval for an ancillary device**

10.2.12.1 When an ancillary device that repeats primary indications is intended to be approved separately, its indications shall be compared with those provided by an indicating device that has already been approved and which has the same scale interval, or a smaller one. The results shall satisfy the provisions in 7.1.4.5.

As far as necessary, conditions for compatibility with other devices of a measuring system are stated in the type approval certificate.

10.2.12.2 Electronic devices may be approved separately when they are used for the transmission of primary indications or other necessary information. For example, a device which receives information from two or more calculators and transmits it to a single printing device.

When at least one of the signals of this information is analog, the device shall be tested in association with another device whose maximum permissible errors are specified in this Recommendation.

When all the signals of this information are digital, the above provision may be applied; however, when the inputs and outputs of the device are available, the device may be tested separately, in which case no error shall be introduced; only errors due to the testing method may be found out.

In both cases and as far as necessary, the required conditions for compatibility with other devices of a measuring system are stated in the type approval certificate.

**10.3 Initial verification**

The initial verification consists in verifying that the measuring system fulfils the full set of metrological requirements applicable to the measuring system on the site of use.

*Note:* This does not mean that each provision in this Recommendation is checked at initial verification and that each test or examination is performed on the site of use (see 10.1.1).

### 10.3.1 Initial verification of a metering module

10.3.1.1 Excepted when the type approval certificate provides specific provisions, the initial verification of a metering module is performed:

- on the complete flowrate range of the metering module;
- under rated operating conditions (pressure, temperature, etc.);
- with the gas(es) to be measured.

When the type approval certificate provides specific provisions, as far as necessary, it also provides any correction and/or condition to be applied.

10.3.1.2 There are several ways to obtain the assurance that the metering module fulfils the full set of requirements.

The ideal way consists in performing the complete verification on the actual site of use.

However, all tests may not be possible on site: for instance every actual flowrate may not be achievable on the day of verification. In this case it is necessary to perform the verification in two stages.

Moreover tests (or some tests) on the actual site of use are not necessary when it can be demonstrated that the corresponding tests performed on a test bench are representative of the actual situation and when the behavior of the system is not likely to be influenced by disassembling, transportation and reassembling. In this case the second stage of the verification, if appropriate, does not need to include tests (or all tests) but may only consist in an examination.

In any case, for technologies which are not mentioned in Annex B the initial verification shall always include a metrological evaluation on the actual site of use.

10.3.1.3 In the case of a first stage of the verification, as far as possible, the separate verification of the flow measuring device and of the calculator may be considered.

In any case, any ancillary or additional device likely to influence the performance of the system shall be present at each stage of the verification.

10.3.1.4 The initial verification includes correction as close as possible to zero of individual errors by means of the correction device or of the *WME* by means of the adjustment device. After correction or adjustment, all errors shall be or shall be able to be considered within mpes. After correction or adjustment it is advisable to perform a new test in order to confirm the correction or adjustment.

However, it is possible to consider that it is not necessary to adjust the *WME* when the set of following conditions is met:

- in case of the first stage of a verification; and
- it is intended to perform a second stage of verification including accuracy tests in actual site; and
- the error curve is within a range corresponding to the range of applicable mpes.

Then all errors are recorded and the *WME* has to be adjusted at the second stage of verification and the above requirement is checked.

In the case of a correction device and when the correction parameters are determined at the first stage of the verification, the presence of these parameters in the correction device shall be checked at the second stage of verification.

### 10.3.2 Initial verification of conversion devices

The initial verification of conversion devices is performed in one or two stages.

In any case it includes at least examination on the actual site of use.

Compliance with the requirements shall be checked after adjustment of the instrument.

Several calibration gases shall be used with calorific values equally spaced on the long-term CV-range for the installation site.

### **10.3.3 Initial verification of a measuring system**

The initial verification includes the tests below and the examinations performed according to the provisions in 10.3.1 and 10.3.2:

- 1 An examination of the conformity of the measuring system and of all its elements;
- 2 Metrological testing and examination of the metering module;
- 3 Metrological testing and examination of the volume conversion device and of relevant associated measuring instruments, if applicable;
- 4 Metrological testing and examination of the energy conversion device and of the calorific value determining device, if applicable;
- 5 An examination of the suitability of documented provisions, if applicable.

### **10.4 Subsequent verifications**

Subsequent verifications may be identical to initial verification.

### **10.5 Documented provisions, quality assurance systems and routine controls**

10.5.1 According to the definition of a measuring system a documented provisions system may be considered as an integral part of the measuring system (see D.1).

Moreover, a quality assurance system may be considered as essential to ensure the correct use and the fundamental integrity of the installation. This may be particularly important for the calibration and the maintenance of calorific value determining devices when they are subject to calibration procedures by the user. During operation, the fundamental integrity shall be preserved.

When documented provisions and if applicable the quality assurance system are necessary for ensuring the performance and/or the integrity of the measuring system, they shall be part of the measuring system and mandatory provisions, and shall be enforced as such.

10.5.2 The documented provisions, the quality assurance system or the regulation may foresee that routine tests are performed. The results of the routine tests shall be compared to pre-established limits and the differences shall result in appropriate reactions.

## Annex A

### Performance environmental influence tests for electronic measuring systems or devices

#### (Mandatory)

#### A.1 General

This Annex defines the program of performance tests intended to verify that electronic measuring systems or electronic devices perform and function as intended in a specified environment and under specified conditions. Each test indicates, where appropriate, the reference conditions for determining the intrinsic error.

These tests supplement any other prescribed test.

When the effect of one influence quantity is being evaluated, all other influence quantities shall be held at values within the limits of reference conditions.

#### A.2 Severity levels (see OIML D 11 [6])

For each performance test, typical test conditions are indicated: they correspond to the climatic and mechanical environment conditions to which measuring systems are usually exposed.

Measuring systems are divided into two classes according to climatic and mechanical environmental conditions:

- class I for fixed instruments or devices installed in a building;
- class O for fixed instruments or devices installed outdoors.

However, the applicant for type approval may indicate specific environmental conditions in the documentation supplied to the metrology service, based on the intended use of the instrument or devices. In this case, the metrology service carries out performance tests at severity levels corresponding to these environmental conditions. If type approval is granted, the data plate shall indicate the corresponding limits of use. Manufacturers shall inform potential users of the conditions of use for which the instrument is approved. The metrology service shall verify that the conditions of use are met.

#### A.3 Reference conditions

Ambient temperature	: $20\text{ °C} \pm 5\text{ °C}$
Temperature of the gas 1) 2)	: Nominal operating conditions declared by the manufacturer $\pm 5\text{ °C}$
Relative humidity	: $60\% \pm 15\%$
Atmospheric pressure	: 86 kPa to 106 kPa
Power voltage	: Nominal voltage ( $U_{\text{nom}}$ )
Power frequency	: Nominal frequency ( $f_{\text{nom}}$ )
Flowrate (if relevant)	: $0.95 Q_{\text{max}}$ to $Q_{\text{max}}$

- 1) For parts of the metering module that require to be tested with gas
- 2) Substitute gas may be used for security reasons

During each test, the temperature and relative humidity shall not vary by more than  $5\text{ °C}$  or  $10\%$  respectively within the reference range.

#### A.4 Performance tests

The following tests can be carried out in any order.

Test		Nature of the influence quantity	Severity level for class (referring to D 11)	
			I	O
A.4.1	Dry heat	Influence factor	2	3
A.4.2	Cold	Influence factor	2	3
A.4.3.a	Damp heat, steady state	Influence factor	1	2
A.4.3.b	Damp heat, cyclic	Disturbance	1	2
A.4.4	Vibration (random)	Influence factor	1	1
A.4.5.a	Radiated, radio frequency electromagnetic fields of general origin	Disturbance	3	3
A.4.5.b	Radiated, radio frequency electromagnetic fields caused by digital radio telephones	Disturbance	3	3
A.4.6	Conducted radio frequency fields	Disturbance	3	3
A.4.7	Electrostatic discharge	Disturbance	3	3
A.4.8	Surges on signal, data and control lines	Disturbance	3	3
A.4.9	DC mains voltage variation	Influence factor	-	-
A.4.10	AC mains voltage variation	Influence factor	1	1
A.4.11	AC mains voltage dips, short interruptions, and voltage variations	Disturbance	2	2
A.4.12	Bursts (transients) on AC and DC mains and on signal lines	Disturbance	3	3
A.4.13	Surges on AC and DC mains power lines	Disturbance	3	3
A.4.14	Voltage of internal battery	Influence factor	1	1

For EMC tests the severity levels are those corresponding to industrial environments. The above tests involve the electronic part of the measuring system or its devices.

The following rules shall be taken into consideration for these tests:

##### 1) Test quantities

Some influence quantities are likely to have a constant effect on measurement results and not a proportional effect related to the measured quantity. The value of the significant fault is related to the measured quantity; therefore, in order to be able to compare results obtained in different laboratories, it is necessary to perform a test on a quantity corresponding to that delivered in one minute at the maximum flowrate, but not less than a quantity corresponding to the appropriate number of scale intervals specified in Annex F. Some tests, however, may require more than one minute, in which case they shall be carried out in the shortest possible time.

##### 2) Influence of the gas temperature

Temperature tests concern the ambient temperature and not the temperature of the gas used. It is therefore advisable to use a simulation test method so that the temperature of the gas does not influence the test results.

##### 3) Atmospheric pressure

The pressure shall be maintained at reference conditions for all the tests.

**A.4.1 Dry heat**

Applicable standards:	IEC 60068-2-2 [14] IEC 60068-3-1 [15]
Test method:	Dry heat (non condensing)
Object of the test:	To verify compliance with the provisions in 9.1.1 under conditions of high temperature
Test procedure in brief (*):	The test consists of exposure of the EUT to a temperature of 55 °C (class C) or 40 °C (class B) under "free air" conditions for a 2-hour period after the EUT has reached temperature stability. The EUT shall be tested at at least one flow rate (or simulated flowrate): <ul style="list-style-type: none"> <li>▪ at the reference temperature of 20 °C following conditioning,</li> <li>▪ at the temperature of 55 °C or 40 °C, 2 hours after temperature stabilization,</li> <li>▪ after recovery of the EUT at the reference temperature of 20 °C.</li> </ul>
Test severities:	1) Temperature: <ul style="list-style-type: none"> <li>▪ severity level 2: 40 °C</li> <li>▪ severity level 3: 55 °C</li> </ul> 2) Duration: 2 hours
Number of test cycles:	One cycle
Maximum allowable variations:	<ul style="list-style-type: none"> <li>▪ All functions shall operate as designed and</li> <li>▪ all errors shall be within the maximum permissible errors.</li> </ul>
(*) This test procedure has been given in condensed form, for information only, and is adapted from the referenced IEC publication. Before conducting the test, the applicable publication should be consulted. This comment also applies to the test procedures hereafter.	

**A.4.2 Cold**

Applicable standards:	IEC 60068-2-1 [13] IEC 60068-3-1 [15]
Test method:	Cold
Object of the test:	To verify compliance with the provisions in 9.1.1 under conditions of low temperature
Test procedure in brief:	The test consists of exposure of EUT to a temperature of –25 °C (class C) or –10 °C (class B) under "free air" conditions for a 2-hour period after the EUT has reached temperature stability. The EUT shall be tested at at least one flow rate (or simulated flow rate): <ul style="list-style-type: none"> <li>▪ at the reference temperature of 20 °C following conditioning,</li> <li>▪ at a temperature of –25 °C or –10 °C, 2 hours after temperature stabilization,</li> <li>▪ after recovery of the EUT at the reference temperature of 20 °C.</li> </ul>
Test severities:	1) Temperature: <ul style="list-style-type: none"> <li>▪ severity level 2: –10 °C</li> <li>▪ severity level 3: –25 °C</li> </ul> 2) Duration: 2 hours
Number of test cycles:	One cycle
Maximum allowable variations:	<ul style="list-style-type: none"> <li>▪ All functions shall operate as designed and</li> <li>▪ all errors shall be within the maximum permissible errors.</li> </ul>

**A.4.3 Damp heat****A.4.3.a Damp heat, steady state (non condensing)**

Applicable standards:	IEC 60068-2-78 [21] IEC 60068-3-4 [16]			
Test method:	Damp heat, steady-state			
Object of the test:	To verify compliance with the provisions in 9.1.1 under conditions of high humidity and constant temperature.  The steady-state test should always be used where adsorption or absorption play the main part. When diffusion but not breathing is involved, either the steady-state or the cyclic test shall be applied depending on the type of EUT and its application.			
Test procedure in brief:	The test consists of exposure of the EUT to the specified high level temperature and the specified constant relative humidity for a certain fixed time defined by the severity level. The EUT shall be handled such that no condensation of water occurs on it.			
Test severities:	Severity level	1	2	
	Temperature	30	40	°C
	Humidity	85	93	% rel
	Duration	2	4	days
Maximum allowable variations:	After the application of the influence factor and recovery: <ul style="list-style-type: none"> <li>▪ All functions shall operate as designed and</li> <li>▪ all errors shall be within the maximum permissible errors.</li> </ul>			

**A.4.3.b Damp heat, cyclic (condensing)**

Applicable standards:	IEC 60068-3-4 [16] IEC 60068-2-30 [17]			
Test method:	Damp heat, cyclic			
Object of the test:	To verify compliance with the provisions in 9.1.1 under conditions of high humidity when combined with cyclic temperature changes.  Cyclic tests shall be applied in all the cases where condensation is important or when the penetration of vapor will be accelerated by the breathing effect.			



Test procedure in brief:	<p>The test consists of exposure of the EUT to cyclic temperature variations between, 25 °C and the upper temperature of 55 °C (class C) or 40 °C (class B), maintaining the relative humidity above 95 % during the temperature changes and during the phases at low temperature, and at 93 % at the upper temperature phases. Condensation should occur on the EUT during the temperature rise.</p> <p>The 24 h cycle consists of:</p> <ol style="list-style-type: none"> <li>1) temperature rise during 3 h</li> <li>2) temperature maintained at upper value until 12 h from the start of the cycle</li> <li>3) temperature lowered to lower value within 3 h to 6 h, the rate of fall during the first hour and a half being such that the lower value would be reached in 3 h</li> <li>4) temperature maintained at lower value until the 24 h cycle is completed.</li> </ol> <p>The stabilizing period before and recovery after the cyclic exposure shall be such that all parts of the EUT are within 3 °C of their final temperature.</p> <p>The EUT is not under power when the disturbance is applied.</p>
Test severities:	<ol style="list-style-type: none"> <li>1) Upper temperature: <ul style="list-style-type: none"> <li>▪ severity level 1: 40 °C</li> <li>▪ severity level 2: 55 °C</li> </ul> </li> <li>2) Duration: 24 hours</li> </ol>
Number of test cycles:	Two cycles
Maximum allowable variations:	After the application of the disturbance and recovery either the difference between any indication before the test and the indication after the test shall not exceed the values given in T.2.17 or the measuring system shall detect and act upon a significant fault, in compliance with 9.3.1.

**A.4.4 Vibration (random)**

Applicable standard:	IEC 60068-2-64 [20] IEC 60068-2-47 [19]		
Test method:	Random vibration		
Object of the test:	To verify compliance with the provisions in 9.1.1 under conditions of random vibration.		
Test procedure in brief:	<p>The EUT shall, in turn, be tested in three, mutually perpendicular axes mounted on a rigid fixture by its normal mounting means.</p> <p>The EUT shall normally be mounted so that the gravitational force acts in the same direction as it would in normal use. Where the effect of gravitational force is not important the EUT may be mounted in any position.</p> <p>When the influence factor is applied, the EUT:</p> <ul style="list-style-type: none"> <li>▪ is not under power,</li> <li>▪ is not mounted on a piping system,</li> <li>▪ is not put in any protection case.</li> </ul>		
Test severity:	Severity level	1	Unit
	Total frequency range	10–150	Hz
	Total RMS level	1.6	$\text{m}\cdot\text{s}^{-2}$
	ASD level 10–20 Hz	0.05	$\text{m}^2\cdot\text{s}^{-3}$
	ASD level 20–150 Hz	–3	dB/octave
	Duration per axis (or a longer period if necessary for carrying out the measurement)	2	min
Maximum allowable errors:	<p>After the application of the influence factor:</p> <ul style="list-style-type: none"> <li>▪ All functions shall operate as designed and</li> <li>▪ all errors shall be within the maximum permissible errors.</li> </ul>		

**A.4.5 Radio frequency immunity**

Applicable standard:	IEC 61000-4-3 [26]		
Test method:	Radiated electromagnetic fields		
Object of the test:	To verify compliance with the provisions in 9.1.2 under conditions of electromagnetic fields.		
Test procedure in brief:	<p>The EUT shall be exposed to electromagnetic field strength as specified by the severity level and a field uniformity as defined by the referred standard.</p> <p>The EM field can be generated in different facilities, however the use of which is limited by the dimensions of the EUT and the frequency range of the facility.</p>		
Maximum allowable variations:	Either the difference between any indication during the test and the indication under reference conditions shall not exceed the values given in T.2.17 or the measuring system shall detect and act upon a significant fault, in compliance with 9.3.1.		

**A.4.5.a Radiated, radio frequency, electromagnetic fields of general origin**

Severity level		3	unit
Frequency range:	80 – 800 MHz	10	V/m
	960 – 1 400 MHz	10	
Modulation:		80 % AM, 1 kHz, sine wave	

**A.4.5.b Radiated, radio frequency, electromagnetic fields caused by digital radio telephones**

Severity levels		3	unit
Frequency range:	800 – 960 MHz	10	V/m
	1 400 – 2 000 MHz	10	
Modulation:		80 % AM, 1 kHz, sine wave	

**A.4.6 Conducted, radio frequency, electromagnetic fields**

Applicable standard:	IEC 61000-4-6 [29]		
Test method:	Conducted electromagnetic fields		
Object of the test:	To verify compliance with the provisions in 9.1.2 under conditions of electromagnetic fields.		
Test procedure in brief:	Radio frequency EM current, simulating the influence of EM fields shall be coupled or injected into the mains and input ports of the EUT using coupling/decoupling devices as defined in the referred standard. The performance of the test equipment consisting of an RF generator, (de-)coupling devices, attenuators, etc. shall be verified.		
Severity levels:	3	Unit	
RF amplitude (50 Ω):	10	V (e.m.f.)	
Frequency range:	0.15 – 80	MHz	
Modulation:	80 % AM, 1 kHz sine wave		
Maximum allowable variations:	Either the difference between any indication during the test and the indication under reference conditions shall not exceed the values given in T.2.17 or the measuring system shall detect and act upon a significant fault, in compliance with 9.3.1.		

**A.4.7 Electrostatic discharge**

Applicable standard:	IEC 61000-4-2 [25]
Test method:	Electrostatic discharge (ESD)
Object of the test:	To verify compliance with the provisions in 9.1.2 under conditions of direct and indirect electrostatic discharges.

Test procedure in brief:		<p>An ESD generator shall be used with a performance as defined in the referred standard.</p> <p>Before starting the tests, the performance of the generator shall be verified.</p> <p>At least 10 discharges shall be applied. The time interval between successive discharges shall be at least 10 seconds.</p> <p>For EUT not equipped with a ground terminal, the EUT shall be fully discharged between discharges.</p> <p>Contact discharge is the preferred test method. Air discharges shall be used were contact discharge cannot be applied.</p> <p>Direct application:</p> <p>In the contact discharge mode to be carried out on conductive surfaces, the electrode shall be in contact with the EUT.</p> <p>In the air discharge mode on insulated surfaces, the electrode is approached to the EUT and the discharge occurs by spark.</p> <p>Indirect application:</p> <p>The discharges are applied in the contact mode to coupling planes mounted in the vicinity of the EUT.</p>	
Severity levels: <sup>(1)</sup>		3	unit
Test voltage:	contact discharge	6	kV
	air discharge	8	kV
Note:		In this case, "level" means up to and including the specified level (i.e. the test shall also be performed at the specified lower levels in the standard).	
Maximum allowable variations:		Either the difference between any indication during the test and the indication under reference conditions shall not exceed the values given in T.2.17 or the measuring system shall detect and act upon a significant fault, in compliance with 9.3.1.	

**A.4.8 Surges on signal, data and control lines**

Applicable standard:	IEC 61000-4-5 [28]		
Test method:	Electrical surges		
Object of the test:	To verify compliance with the provisions in 9.1.2 under conditions where electrical surges are superimposed on I/O and communication ports.		
Test procedure in brief:	<p>A surge generator shall be used with the performance characteristics as specified in the referred standard. The test consists of exposure to surges for which the rise time, pulse width, peak values of the output voltage/current on high/low impedance load and minimum time interval between two successive pulses are defined in the referred standard.</p> <p>The characteristics of the generator shall be verified before connecting the EUT. At least 3 positive and 3 negative surges shall be applied. The injection network depends on the lines the surge is coupled into and is defined in the referred standard.</p> <p>If the EUT is an integrating instrument (meter), the test pulses shall be continuously applied during the measuring time.</p>		
Severity level: (Installation class)	3	unit	
Unbalanced lines:	Line to line	1.0	kV
	Line to earth	2.0 <sup>(1)</sup>	kV
Balanced lines:	Line to line	N.A.	-
	Line to earth	2.0	kV
Notes:	<sup>(1)</sup> Normally tested with primary protection		
Maximum allowable variations:	After the application of the disturbance and recovery, either the difference between any indication before the test and the indication after the test shall not exceed the values given in T.2.17 or the measuring system shall detect and act upon a significant fault, in compliance with 9.3.1.		

**A.4.9 DC mains voltage variation (if relevant)**

Applicable standard:	IEC 60654-2 [22]		
Test method:	Variation in DC mains power voltage		
Object of the test:	To verify compliance with the provisions in 9.1.1 under conditions of varying DC mains power voltage (if relevant).		
Test procedure in brief:	The test consists of exposure to the specified power supply condition for a period sufficient for establishing stability.		
Test severity:	<p>The upper limit will be the DC level at which the EUT has been manufactured to automatically detect high-level conditions.</p> <p>The lower limit will be the DC level at which the EUT has been manufactured to automatically detect low-level conditions.</p> <p>The EUT shall comply with the specified maximum permissible errors at voltage levels between the two levels.</p>		
Maximum allowable variations:	<ul style="list-style-type: none"> <li>▪ All functions shall operate as designed and</li> <li>▪ all errors shall be within the maximum permissible errors.</li> </ul>		

**A.4.10 AC mains voltage variation**

Applicable standards:	IEC/TR3 61000-2-1 [39] IEC 61000-2-2 [23] IEC 61000-4-1 [24]
Test method:	Variation in AC mains power voltage and frequency (single phase)
Object of the test:	To verify compliance with the provisions in 9.1.1 under conditions of varying AC mains power voltage and frequency.
Test procedure in brief:	The test consists of exposure of the EUT to power voltage variations, while the EUT is operating under normal atmospheric conditions.
Test severities:	Mains voltage: upper limit: $U_{nom} + 10\%$ lower limit: $U_{nom} - 15\%$
Number of test cycles:	One cycle
Maximum allowable variations:	<ul style="list-style-type: none"> <li>▪ All functions shall operate as designed and</li> <li>▪ all errors shall be within the maximum permissible errors.</li> </ul>

**A.4.11 AC mains voltage dips, short interruptions, and voltage variations**

Applicable standards:	IEC 61000-4-11 [30] IEC 61000-6-1 [31] IEC 61000-6-2 [32]				
Test method:	Short-time reductions in mains voltage				
Object of the test:	To verify compliance with the provisions in 9.1.2 under conditions of short time mains voltage reductions.				
Test procedure in brief:	<p>A test generator is used which is suitable to reduce the amplitude of the AC mains voltage for a defined period of time.</p> <p>The performance of the test generator shall be verified before connecting the EUT.</p> <p>The mains voltage reductions shall be repeated 10 times with an interval of at least 10 seconds.</p>				
Severity level:	2			Unit	
Test:	test a	test b	test c		
Voltage reduction:	Reduction	0	0	70	%
	Duration	0.5	1	25/30	periods
Voltage interruption:	Interruption	> 95			%
	Duration	250/300			periods
Maximum allowable variations:	Either the difference between any indication during the test and the indication under reference conditions shall not exceed the values given in T.2.17 or the measuring system shall detect and act upon a significant fault, in compliance with 9.3.1.				
Notes:					
<p>The severity levels are an interpretation of IEC 61000-4-11 [30] and according to IEC 61000-6-1 [31] and IEC 61000-6-2 [32].</p> <p>The value 0 as “reduction” does not mean that the reduction is nil. See the signification of this parameter in the appropriate standard.</p>					

**A.4.12 Bursts (transients) on AC and DC mains and on signal lines**

Applicable standards:	IEC 61000-4-1 [24] IEC 61000-4-4 [27]		
Test method:	Electrical bursts		
Object of the test:	To verify compliance with the provisions in 9.1.2 under conditions where electrical bursts are superimposed on the mains voltage and if applicable on input/output and communication ports.		
Test procedure in brief:	<p>A burst generator shall be used with the performance characteristics as specified in the referred standard.</p> <p>The test consists of exposure to bursts of voltage spikes for which the repetition frequency of the impulses and peak values of the output voltage on a 50 <math>\Omega</math> load are defined in the referred standard.</p> <p>The characteristics of the generator shall be verified before connecting the EUT.</p> <p>At least 10 positive and 10 negative randomly phased bursts shall be applied.</p> <p>The injection network on the mains shall contain blocking filters to prevent the burst energy from being dissipated in the mains.</p> <p>For the coupling of the bursts into the input/output and communication lines, a capacitive coupling clamp as defined in the standard shall be used.</p>		
Severity levels:	3	unit	
Amplitude (peak value):	Supply lines <sup>(1)</sup>	2	kV
	Signal lines <sup>(2)</sup>	1	kV
Repetition rate:	5	kHz	
Maximum allowable variations:	Either the difference between any indication during the test and the indication under reference conditions shall not exceed the values given in T.2.17 or the measuring system shall detect and act upon a significant fault, in compliance with 9.3.1.		
Notes:			
<sup>(1)</sup> Only for instruments powered by AC or DC mains power supply.			
<sup>(2)</sup> I/O signal, data and control ports.			

**A.4.13 Surges on AC and DC mains power lines**

Applicable standard:	IEC 61000-4-5 [28]	
Test method:	Electrical surges	
Object of the test:	To verify compliance with the provisions in 5.1.1 or 5.1.2 under conditions where electrical surges are superimposed on the mains voltage.	
Test procedure in brief:	<p>A surge generator shall be used with the performance characteristics as specified in the referred standard. The test consists of exposure to surges for which the rise time, pulse width, peak values of the output voltage/current on high/low impedance load and minimum time interval between two successive pulses are defined in the referred standard.</p> <p>The characteristics of the generator shall be verified before connecting the EUT. On AC mains supply lines at least 3 positive and 3 negative surges shall be applied synchronously with AC supply voltage in angles 0°, 90°, 180° and 270°. On DC power lines, at least 3 positive and 3 negative surges shall be applied. The injection network depends on the lines the surge is coupled into and is defined in the referred standard.</p> <p>If the EUT is an integrating instrument, the test pulses shall be continuously applied during the measuring time.</p>	
Severity level: (installation class)	3	unit
Line to line:	1.0	kV
Line to earth:	2.0	kV
Maximum allowable variations:	After the application of the disturbance and recovery, either the difference between any indication before the test and the indication after the test shall not exceed the values given in T.2.17 or the measuring system shall detect and act upon a significant fault, in compliance with 9.3.1.	



**A.4.14 Voltage of internal battery (if relevant)**

Applicable standards:	There is no reference to standards for this test.
Test method:	Variation in supply voltage
Object of the test:	To verify compliance with the provisions in 9.1.1 under conditions of low battery voltage.
Test procedure:	<p>The test consists of exposure to the specified condition of the battery(s) for a period sufficient for achieving temperature stability and for performing the required measurements.</p> <p>If an alternative power source (standard power supply with sufficient current capacity) is used in bench testing to simulate the battery, it is important that the internal impedance of the specified type of battery also be simulated.</p> <p>The maximum internal impedance of the battery is to be specified by the manufacturer of the instrument.</p> <p>Test sequence:</p> <p>Stabilize the power supply at a voltage within the defined limits and apply the measurement and/or loading condition. Record the following data:</p> <ol style="list-style-type: none"> <li>a) date and time</li> <li>b) temperature</li> <li>c) power supply voltage</li> <li>d) functional mode</li> <li>e) measurements and/or loading condition</li> <li>f) indications (as applicable)</li> <li>g) errors</li> <li>h) functional performance</li> </ol> <p>Reduce the power voltage to the EUT until the equipment clearly ceases to function properly according to the specifications and metrological requirements, and note the following data:</p> <ol style="list-style-type: none"> <li>i) power supply voltage</li> <li>j) indications</li> <li>k) errors</li> <li>l) other relevant responses of the instrument</li> </ol>
Lower limit of the voltage:	The lowest voltage at which the EUT functions properly according to the specifications.
Number of cycles:	At least one test cycle for each functional mode
Maximum allowable variations:	<ul style="list-style-type: none"> <li>▪ All functions shall operate as designed and</li> <li>▪ all errors shall be within the maximum permissible errors.</li> </ul>

## **Annex B**

### **Influence tests for type approval of metering modules**

#### **(Mandatory)**

This Annex provides the influence test conditions for a metering module and maximum allowable influences. These tests have to be performed for all technologies.

However, tests for hydraulic influence are particularly adapted for the well known technologies considered in this Annex, i.e.:

- turbine meters;
- rotary piston meters;
- orifice plate meters;
- ultrasonic meters;
- vortex meters;
- Coriolis mass meters.

This is the reason why the complete modular approach is only possible for these technologies. For other technologies tests on site are always necessary (in addition to the following) at type approval and on initial verification. Nevertheless, as indicated in 10.2.6.2.3, the legal authority may require tests in real conditions of use for all technologies.

Moreover, if the provisions in B.2 are applicable to any metering module, some specific provisions may be applied for specific technologies or for particular cases as laid down in B.7.

#### **B.1 General provisions**

According to the way in which the meter is installed, in particular the straight lengths of the pipe upstream of the meter, the same meter may belong to metering modules of different accuracy classes.

The minimum straight lengths, other necessary conditions (presence of flow conditioner, etc.) and the corresponding accuracy classes shall be indicated in the type approval certificate.

#### **B.2 Pipework installation influence**

B.2.1 The minimum straight lengths upstream of the meter shall be at least twice the nominal inlet diameter of the meter unless the manufacturer specifies a larger length. The minimum straight length downstream of the meter shall be specified by the manufacturer.

This Recommendation encourages the installation of pressure reducers downstream of meters. In any case, the type approval certificate of a metering module shall include information on the possibility or not of the presence of a pressure reducer upstream of a meter in conformity with the following:

- For a class A metering module, either a pressure reducer shall never be installed with an upstream straight length less than 50 times the nominal inlet diameter of the meter, or the metering module shall be tested with the actual intended type of pressure reducer at type approval and on the site of installation at initial verification or after each maintenance operation likely to influence the metrological performances.
- For class B or C metering modules either a pressure reducer shall never be installed with an upstream straight length less than 10 times the nominal inlet diameter of the meter, or the metering module shall be tested with the actual intended type of pressure reducer and the type approval certificate shall indicate this actual intended type of pressure reducer and the effective upstream straight length.

These provisions apply without prejudice to B.7 for specific technologies.

B.2.2 The metering module shall be submitted to the following tests for the influence of flow disturbances with the corresponding devices upstream of the meter.

These tests are performed at stable gas pressure and temperature.

#### **First test**

The test configurations are those in B.2.1 in OIML R 137-1. According to the manufacturer's choice, the upstream straight length can be greater than twice the inlet diameter of the meter.

The tests are performed for configurations a and b as indicated in OIML R 137-1.

#### **Second test**

The test configuration is the one in B.3.1 in OIML R 137-1. According to the manufacturer's choice, the upstream straight length can be greater than twice the inlet diameter of the meter.

#### **Third test**

The manufacturer shall specify the minimum distance at which a pressure reducer may be located upstream of the meter.

The third test is not applicable when this distance is greater than or equal to respectively 50 times the nominal inlet diameter of the meter for class A and 10 times the nominal inlet diameter of the meter for classes B and C.

When the metering module needs to be tested, as a consequence of B.2.1, the pressure reducer is of the actual intended type.

The minimum distance and the intended effective type specified by the manufacturer are put in the type approval certificate.

The deviation of errors with and without the pressure reducer (without adjustment of the meter) shall be recorded.

#### **Acceptance criteria**

For the first and second tests, if the metering module only consists in a meter and an upstream straight length of twice (or another value specified by the manufacturer of the meter) the inlet diameter (and the same for downstream), the maximum permissible influence, positive or negative, is 0.33 %.

The largest effective influence in absolute value for above tests is hereafter called  $\Delta F$  in order to calculate the global influence as laid down in B.5. However, the figures corresponding to the third test are not taken into consideration when the metering module is intended to be tested on the site of installation with the presence of the effective pressure reducer.

*Note:* The metering module is made up of the meter and straight lengths as declared by the manufacturer, taking into account the presence of a pressure reducer as laid down above.

### **B.3 Influence of gas pressure**

The metering module shall be submitted to a test for the influence of gas pressure. However, in practice it is possible to perform this test on the meter alone if according to the technology of the meter it can be assumed that the conclusion of the test would be the same.

This test should be performed with gaseous fuel and at a stable gas temperature. However, other gases may be used if the equivalency has been preliminary demonstrated.

#### **Test**

The test consists in determining and comparing the error curve at the nominal gas pressure as declared by the manufacturer with the error curves at the lowest and the highest gas pressures as declared by the manufacturer.

*Note:* The test may be performed at a lower pressure than the highest pressure if it is established that it would not have a significant influence on the test result. However, a minimum test pressure of 20 bar is required (if the highest value is greater).

**Acceptance criterion**

The influence of gas pressure, positive or negative, shall not exceed 0.5 %. The larger effective influence in absolute value is hereafter called  $\Delta P$  in order to calculate the global influence as laid down in B.5.

**B.4 Influence of gas temperature**

The metering module should be submitted to a test for the influence of gas temperature. This test, called the “basic test”, should be performed with gaseous fuel at a stable gas pressure. However, other gases might be used if the equivalency has first been demonstrated.

Moreover, this test is not easy to perform in practice. As a consequence the following rules apply:

- 1 For technologies mentioned in the introduction to this Annex, no test or investigation are necessary when rated operating conditions for gas temperature are in the range 5 °C to 30 °C.
- 2 In all other cases it is allowed not to perform the basic test if the influence of the gas temperature can be evaluated implementing any substitute testing and/or investigation.

If a test is performed (basic or not), it is possible to perform it on the meter alone if according to the technology of the meter it is established that the conclusion of the test would be the same.

**Basic test**

The basic test consists in determining and comparing the error curve at the nominal gas temperature as declared by the manufacturer with the error curves at the lowest and the highest gas temperatures as declared by the manufacturer.

**Acceptance criterion**

If the basic test is performed, the larger effective influence in absolute value is recorded and hereafter called  $\Delta T$  in order to calculate the global influence as laid down in B.5.

If the basic test is not performed, any evaluation implementing any substitute testing and/or investigation shall lead to the conclusion that the influence of gas temperature should be smaller than or equal to 0.5.

If the basic test is not performed, in any case the influence of gas temperature  $\Delta T$  is taken as conventionally equal to 0.5 % in order to calculate the global influence as laid down in B.5.

**B.5 Global influence**

The global influence  $\Delta I$  of the above influence quantities or parameters is calculated with the following formula:

$$\Delta I = [(\Delta F)^2 + (\Delta P)^2 + (\Delta T)^2]^{1/2}$$

Where the signification of  $\Delta F$ ,  $\Delta P$  and  $\Delta T$  is given above.

The largest individual error in absolute value recorded according to 10.2.6.1 is called  $E_n$ .

The largest individual error at metering conditions  $E_m$  is calculated with the following formula:

$$E_m = [(E_n)^2 + (\Delta I)^2]^{1/2}$$

This value shall be smaller than or equal to the maximum permissible error laid down in Table 2.

**B.6 mpes at initial verification****B.6.1 mpes at the first stage of initial verification**

Assuming that the influence tests are reproducible for the type, the results above are used to determine mpes at the first stage of initial verification.

The mpes at the first stage of initial verification (mpe1), positive or negative, are calculated using the following formula:

$$(B1)^2 = (\text{mpe1})^2 + (\Delta F)^2 + (\Delta P)^2 + (\Delta T)^2$$

Where:

- B1 is the value laid down first line of Table 2 for the appropriate accuracy class;
- $\Delta F$ ,  $\Delta P$ ,  $\Delta T$  are above values.

*Note:* mpe1 are applicable to individual measurement results, and not to the mean values of errors.

#### B.6.2 mpes at the second stage of initial verification

mpes at the second stage of initial verification, positive or negative, are the values laid down first line of Table 2 for the appropriate accuracy class (B1).

*Note:* B1 is applicable to individual measurement results, and not to the mean values of errors.

### B.7 Specific cases

#### B.7.1 Orifice plate meters

Tests laid down in B.2 to B.4 are not necessary for a metering module with an orifice plate meter when built, installed, operated and verified according to ISO 5167 [40] [41].

In this case the metering module is considered to meet the requirements for class A when it is installed in the best conditions foreseen in ISO 5167 [40] [41] and fitted with class A associated measuring instruments.

The metering module may also meet requirements for other classes when installed in appropriate other conditions specified in this standard and to be indicated in the type approval certificate.

#### B.7.2 Piston rotary meters

When the corresponding tests are not performed,  $\Delta F$  is considered to be equal to 0.33 %.

Tests for the influence of pressure are not necessary. When these tests are not performed  $\Delta P$  is considered to be equal to 0.5 %.

The provisions in B.2 concerning pressure reducers are not applicable to piston rotary meters.

#### B.7.3 Approval of a single metering module (unit type approval)

When a metering module is designed, constructed and installed as a single module (unit type approval) tests in B.2.1 may be replaced by tests at the actual site of use provided that the test conditions are representative of all critical conditions likely to occur on site.

This does not prevent other tests in this Annex from being performed and the provisions in B.5 and B.6 from being applied.

Each test result shall fulfill the mpes at metering conditions laid down in Table 2 in 6.2.1. The influence to be used for applying the provisions in B.5 and B.6 is the largest difference between the tests at nominal conditions and those at each critical condition. When the nominal conditions are unknown, the results at nominal conditions are chosen as the mean values of tests in critical conditions.

## Annex C

### Principles of the modular approach and of error calculation

**(Mandatory as far as principles are concerned)**  
**(Informative as far as examples are concerned)**

#### C.1 Principles

C.1.1 The modular approach is based on the fact that specific maximum permissible errors are applicable to each of the following functions (see Table 2):

- measuring at metering conditions;
- converting at base conditions;
- converting into energy.

Moreover for metering, specific maximum permissible errors may be applied separately for:

- the meter (corrected if necessary);
- influences on the meter (see Annex B).

Starting from these modular maximum permissible errors, the global maximum permissible errors can be calculated for the complete system (see Table 1) using the square root of the sum of all the relevant square maximum permissible errors (see example in C.2).

The same approach may be used for approval of a conversion device.

C.1.2 When calculating the error of a measuring system or of a device the following rules apply, unless specific provisions are provided:

- 1 Where the effective errors of the components or modules are known, they are taken into consideration.
- 2 Where the errors are not known (but the errors fulfill the maximum permissible errors for the relevant module or device), the maximum permissible errors for the components are considered, whether the corresponding parameters are measured or not. In this latter case, the documented provisions system shall ensure that the uncertainty of the non measured parameters is at least as good as the corresponding mpe (see examples in C.3).
- 3 In any case a module has to fulfill its own applicable mpes.

Examples:

- for a class C measuring system, where the calorific value is not measured locally the documented provisions shall ensure a global uncertainty/error for energy conversion of at most 2 % (k=2);
- for a class C measuring system, where the pressure of the gas is not measured for the determination of the converted volume, it is possible to fulfill the requirement with a conversion device using only an associated measuring instrument for temperature which fulfils the requirement in Table 3 provided the documented provisions ensure a global uncertainty/error of at most 1 % for pressure (k=2);

- for a class B measuring system, where the compression factor of the gas is not measured for the determination of the converted volume, it is possible to fulfill the requirement with a conversion device using associated measuring instruments for temperature and pressure which fulfils the requirement in Table 3-1 provided the documented provisions ensure a global uncertainty/error of at most 0.3 % for the compression factor ( $k=2$ ).

C.1.3 The modular approach leads to combining the uncertainties and maximum permissible errors applicable to these elements in order to calculate the errors of the devices including these elements, or of the measuring system.

For this purpose when an error or maximum permissible error has to be combined with standard uncertainties, the coverage factor which is used shall be conventionally equal to 2.

According to the same logic when a combined standard uncertainty is calculated the corresponding expected error shall be equal to twice this value. The conventional error so determined shall be smaller than or equal to the maximum permissible error (see example in C.3).

## C.2 Example of mpe calculation (Class A measuring system)

Module	Modular mpe (%)	Square modular mpe	Measuring system converting at base conditions	Measuring system converting into energy
Metering module	0.7	0.49	0.49	0.49
Conversion at base conditions	0.5	0.25	0.25	0.25
Determination of/conversion into energy	0.6	0.36	---	0.36
Square mpe for measuring system	---	---	0.74	1.10
mpe for measuring system (%)	---	---	0.860 (rounded to 0.9)	1.049 (rounded to 1)

### C.3 Examples of error calculations

#### C.3.1 First example: local CVDD

The purpose of this example is to evaluate the performance of a class A energy measuring system (MS) including the following:

- a class A metering module;
- a class A volume conversion device;
- an energy conversion device involving 2 local calorific value determining devices.

##### C.3.1.1 Error of the metering module (MM)

The MM is fitted with several branches. However, the only available useful information is that the MM meets the mpes under all the rated operating conditions.

The error that will be used for the calculation of the error of the MS is equal to the applicable mpe equal to 0.7 %.

$$E_{MC} = 0.7 \%$$

##### C.3.1.2 Error on volume conversion

The only available useful information is that the volume conversion device meets the mpes under all rated operating conditions.

The error that will be used for the calculation of the error of the MS is equal to the applicable mpe equal to 0.5 %.

$$E_{QC} = 0.5 \%$$

##### C.3.1.3 Error on CV determination

#### **Error of the CVDDs**

The only available useful information is that the CVDDs meet the mpes and all the requirements under all rated operating conditions.

The error that will be used for the calculation of the error on the determination of the CV is equal to the applicable mpe equal to 0.5 %. When only one CVDD is operating the corresponding uncertainty component is:

$$u_{CVDD} = 0.5/2 \%$$

$$u_{CVDD} = 0.25 \%$$

In addition, the errors of the CVDDs may be considered as independent one from another because the CVDDs are of two different types. When the two CVDDs are operating the mean value is considered. The corresponding uncertainty component is:

$$u_{CVDD} = 0.5/2 \sqrt{2} \%$$

$$u_{CVDD} = 0.177 \%$$

#### **Uncertainty on time determination**

For a class A MS this component is equal to zero:

$$u_T = 0$$



### Uncertainty on stability of CV

For each CVDD the CV is determined every 5 min. It is considered that the corresponding uncertainty component is provided by the greatest experimental standard deviation of the mean value ever met. The greatest experimental relative standard deviation (of individual results) ever met is 0.456 %. As 12 measurements an hour are performed to determine the representative CV, the relevant uncertainty component is:

$$u_c = 0.456 / \sqrt{12} \%$$

$$u_c = 0.132 \%$$

### Uncertainty on location

The CVDDs are local so the corresponding uncertainty component is nil:

$$u_L = 0$$

*Note:* If the measuring results provided by these CVDDs are used for remote measuring systems a correction on CV for transit delay may be used with an associated uncertainty.

### Other uncertainties

No other components are identified:

$$u_O = 0$$

### Error on CV determination

In the case of only one CVDD operating, the error on CV determination is equal to:

$$E_{CV} = 2 \times \sqrt{0.25^2 + 0.132^2}$$

$$E_{CV} = 0.57 \%$$

In the case of two CVDDs operating, the error on CV determination is equal to:

$$E_{CV} = 2 \times \sqrt{0.177^2 + 0.132^2}$$

$$E_{CV} = 0.44 \%$$

#### C.3.1.4 Error of the measuring system

All the modules fulfill the applicable mpes and the MS is acceptable.

In the case of 2 CVDDs, the error of the MS could be estimated smaller than or equal to:

$$E_{MS} = \sqrt{0.7^2 + 0.5^2 + 0.44^2} = 0.96 \%$$

### C.3.2 Second example: reconstruction of the CV and a posteriori demonstration

A network is supplied by two gas origins each at one inlet point. A CVDD is used at each inlet point. The network is divided into three zones:

Zone 1: in the vicinity of inlet point 1, the CV is considered to be the one measured at this inlet with a transit delay.

Zone 2: the gas delivered is a mixture of the gases of the 2 origins depending at each time on the consumption of all measuring systems of the network and on the configuration of the network. For each measuring system the gas company uses software, taking into consideration appropriate parameters for determining the local CV. This is the so-called reconstruction procedure.

Zone 3: in the vicinity of inlet point 2, the CV is considered to be the one measured at this inlet with a transit delay.

#### C.3.2.1 Zones 1 and 3

See C.3.1, taking into consideration the note in the paragraph on uncertainty of location. The distinction of the zones 1 and 3 could be interesting in particular in order to consider the case of class A measuring systems without local CVDDs.

#### C.3.2.2 Zone 2

The purpose of this example is to evaluate the performance of a class B energy measuring system including the following:

- a class B metering module;
- a class B volume conversion device;
- an energy conversion device using reconstructed (calculated) values of CV, associated with documented provisions involving in particular transportable CVDDs (possibly in addition fixed ones) on the network, hereafter called checking CVDDs.

##### C.3.2.2.1 Error of the metering module (MM)

The only available useful information is that the MM meets mpes under all rated operating conditions.

##### C.3.2.2.2 Error on volume conversion

The only available useful information is that the volume conversion device meets mpes under all rated operating conditions.

##### C.3.2.2.3 Error on CV determination

It could be possible to imagine calculating the corresponding uncertainty component according to a sophisticated method implemented according to the GUM. However, it was decided to let the gas supply company announce the performance of the software and to compare this announced performance to the experimental performance.

In practice the gas company announces that according to the implemented software and the documented provisions, no true value of CVs on site should deviate from the calculated value determined using the software by more than a stated announced value (AV). However, an allowance may be made for a slight mismatching of these announcements, for example by accident one day in a month, corresponding to a matching level of  $29/30 = 0.966\%$ .

The Authority controls this statement in the following way:

- 1 At the initial demonstration, class A checking CVDDs are used and placed temporarily (possibly in addition to fixed ones) in certain appropriate locations. It is checked that all the calculated CVs (using the software) do not deviate from the CVs measured locally by more than the stated value.
- 2 This assumption is continuously checked, from one location to another, using some class A checking CVDDs.

#### **Error of the CVDDs**

The CVDDs taken into consideration for the calculation of the error are the checking CVDDs. For zone 2, the CVDDs used at the inlet points are part of the documented provisions (as the reconstruction software) but do not have to be considered for the determination of the errors on CV. Nevertheless, the CVDDs at the inlet points need to be subject to legal control because the result of the calorific value is based on them.

The only available useful information is that the checking CVDDs meet mpes and all requirements under all rated operating conditions.

The error that will be used for the calculation of the error on the determination of CV is equal to the applicable mpe, i.e. 0.5 %. The corresponding uncertainty component is:

$$\begin{aligned}u_{CVDD} &= 0.5/2 \% \\ &= 0.25 \%\end{aligned}$$

#### **Uncertainty on time determination**

This component is equal to zero:

$$u_T = 0$$

#### **Uncertainty on stability of the CV**

The stability to be considered may be the stability of the calculated CVs during the period of determination of the representative CV. However, it could be decided to consider the stability observed using the values obtained from checking the CVDDs.

It is considered that the corresponding uncertainty component is provided by the typical experimental standard deviation of the relevant mean values. For this example this typical value is:

$$u_c = 0.227 \%$$

#### **Uncertainty on the location of the CVDD**

Taking into consideration the above demonstration, it is conventionally considered that the uncertainty component on the location of the CVDD is equal to the above value AV divided by 2.

$$u_L = AV/2 \%$$

The announced value is 1 % and therefore:

$$u_L = 0.5 \%$$

*Note:* The demonstration could have led to the conclusion that zone 2 should be split into two zones: one in class B and one in class C for CV determination.

#### **Other uncertainties**

No other components are identified, or more exactly, if any, are considered included in  $u_L$ :

$$u_O = 0$$

#### **Error on CV determination**

The error on CV determination is equal to:

$$\begin{aligned}E_{CV} &= 2 \times \sqrt{0.25^2 + 0.227^2 + 0.5^2} \\ E_{CV} &= 1.21 \%\end{aligned}$$

This value is in conformity with the corresponding line in Table 2.

#### **C.3.2.2.4 Error of the measuring system**

As each module of the metering system fulfils the applicable mpes, the error of the energy metering system is acceptable.

### **C.3.3 Third example: daily average CV assignment**

Consider an area in a network supplied from one inlet point. A class A CVDD is used at the inlet point. The metering systems considered in this area and in this example are class B ones. The mpe for the representative CV determination in this area is therefore 1.25 %.

Assume that this area is flushed at least within one day, i.e. that the gas entering this area leaves it at least in less than one day, either by being consumed or by flowing to downstream areas. This assumption can be demonstrated by taking into account the hydraulic volume of the area and the worst operating conditions,  $T_{\min}$ ,  $P_{\max}$ .

In this case, only two gas qualities may coexist in this area at any time during one day  $j$ , the possible residue of the gas  $G_{j-1}$  which entered it on day  $j-1$ , that may not have been consumed or have left yet, and the arriving gas  $G_j$  during the day  $j$ .

Assume that the daily average CV on day  $j$  is  $CV_j$ , respectively  $CV_{j-1}$  on day  $j-1$ , and  $D_{cv} = |CV_j - CV_{j-1}|$ .

### **Error on the CVDD**

The uncertainty component due to the CVDD that will be used for the calculation of the error on the determination of the CV is equal to the applicable mpe class A, 0.5 %:

$$u_{CVDD} = 0.5/2 \% = 0.25 \%$$

### **Uncertainty on time determination**

On this day,  $u_L = 0$ .

### **Uncertainty on location**

Due to possible intricate connections of the pipes into this area, it may not be possible to determine the exact location of each gas quality.

The gas in this area is assigned during this day an average CV =  $(CV_{j-1} + CV_j)/2$ , with an uncertainty  $(CV_j - CV_{j-1})/\sqrt{12} = D_{cv} / \sqrt{12}$  (rectangular distribution).

$$u_L^2 = D_{cv}^2 / 12$$

### **Uncertainty on stability of CV**

The CV is determined in the class A CVDD every 5 min, leading to  $12 \times 24 = 288$  analyses a day.

Assume that the maximal experimental standard deviation is 0.5 %. The relevant uncertainty component of the mean value is therefore:

$$u_c = 0.5 / \sqrt{288} \% = 0.03 \%$$

Due to the expected range of the CV for the transmitted pipelines gases and to the large number of analyses, this almost always leads to a small figure in practice.

### **Other uncertainties**

No other components are identified.

$$u_0 = 0$$

### **Error on daily representative CV determination**

$$E_{CV} = 2 \times \sqrt{0.25^2 + D_{cv}^2 / 12 + 0.03^2}$$

### **Meeting the requirement in practice:**

For  $D_{cv} = 1.98 \%$ ,  $E_{CV} = 1.25 \%$

In this case, the requirement is met ( $mpe < 1.25\%$ ) as long as the area is flushed within one day, the experimental standard deviation of the daily CV is less than 0.5 % and the variation from one day to the next of the daily average CV,  $D_{cv}$ , is less than or equal to 2 %.

In practice, as long as the gas company provides information according to documented provisions that these three initial assumptions have been met, this gas company is entitled to use this procedure on this area during this period of time for this gas.

According to the general convention used in this Recommendation introducing a coverage factor of 2 (equivalent to a 95 % confidence level assuming a normal distribution), an allowance may be made for a slight mismatching for these criteria, for example by accident one day in a month, corresponding to a matching level of  $29/30 = 0.966\%$ .

#### C.4 Other examples of management of calorific value and energy

##### C.4.1 First example

###### Basic definitions:

"Charging area" is an area for which the gas transporter uses a single calorific value for the calculation of energy conveyed to premises or to pipelines operated by other PGTs.

"Input points" are places at which gas passes from the high pressure national transmission system into the distribution system of the charging area.

An example is a charging area supplied through 4 input points at which gases of different calorific values enter the distribution system.

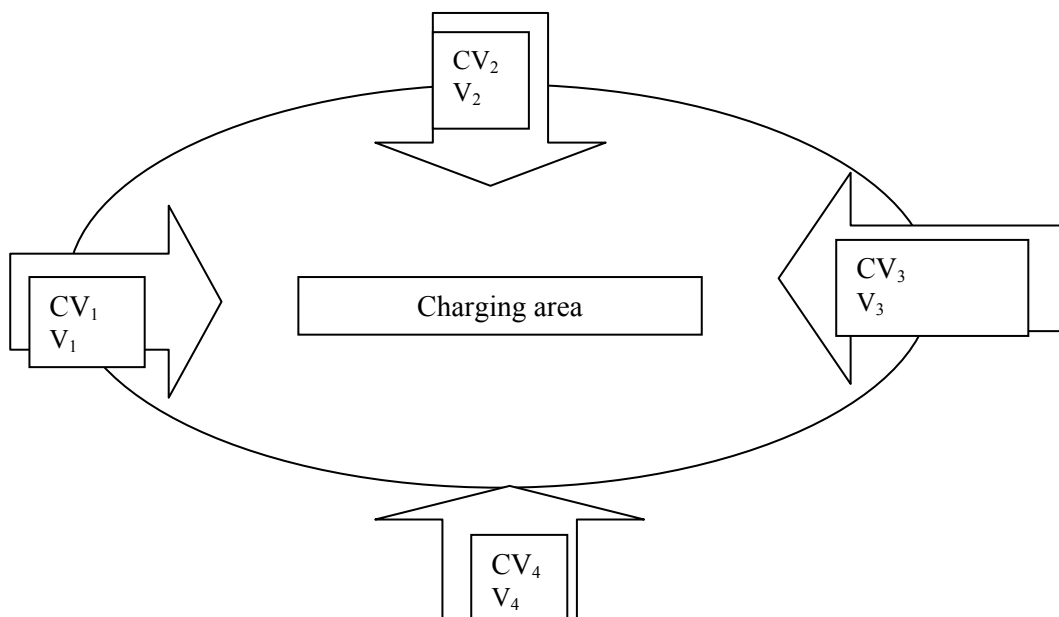

##### A. FIXED ASSIGNMENT BASED ON LOWEST SOURCE CV

The regulation requires that on a daily basis the lowest calorific value of any gas entering the charging area is used in the calculation of the quantity of energy conveyed to premises in the charging area.

In the example the gas passing each of the input points will have its calorific value determined either at the input point or at a point on the high pressure pipeline feeding the point. The lowest calorific value of  $CV_{1-4}$  determined for these input points is assigned to all the interfaces within the charging area (on a daily basis).

There is measurement of CV but volume measurement is not required.

### B. VARIABLE ASSIGNMENT BASED ON FLOW WEIGHTED AVERAGE CV

The regulation requires the calculation of a flow weighted average calorific value (FWACV) for each day from:

$$\text{FWACV} = E/V$$

Where:

E = the sum of all the relevant energy inputs at the input points; and

V = the sum of all the relevant volume inputs at the input points.

For the example:

$$\text{FWACV} = (\text{CV}_1 \cdot \text{V}_1 + \text{CV}_2 \cdot \text{V}_2 + \text{CV}_3 \cdot \text{V}_3 + \text{CV}_4 \cdot \text{V}_4) / (\text{V}_1 + \text{V}_2 + \text{V}_3 + \text{V}_4)$$

This requires each input point to have volume measurement and calorific values to be determined, either in situ or by attribution from elsewhere.

The calorific values are the daily average for the input point and the volumes are the total for the day.

### C.4.2 Second example

Volume meters, conversion devices and calorific value determining devices (CVDDs) together with their relevant additional devices are subject to type approval, initial and final verification and shall be used under approved installation conditions only.

Gas has to be accounted for in terms of energy  $E$  which is calculated from the volume of the gas delivered  $V$  and its representative calorific value  $\overline{H}$ .

The calorific values of differing gases entering a charging area shall be determined at representative sites by approved methods.

The representative calorific value for each site  $x$  ( $\overline{H}_x$ ) can be calculated as the arithmetic or volume weighted mean value. The representative volume weighted monthly mean calorific value  $\overline{H}_x(m)$  (averaged over  $d$  days of the month) is calculated from daily volumes and daily calorific values  $H_x(d)$ , the latter being arithmetically averaged over all  $n$  individual calorific values  $H_{x,n}$ :

$$H_x(d) = \frac{\sum_1^n H_{x,n}}{n} \quad (1)$$

$$\overline{H}_x(m) = \frac{\sum_1^d H_x(d)V(d)}{\sum_1^d V(d)} \quad (2)$$

The representative arithmetically weighted monthly mean calorific value  $H'_x(m)$  is calculated from daily calorific values  $H_x(d)$ :

$$\overline{H}'_x(m) = \frac{\sum_1^d H_x(d)}{d} \quad (2')$$

The representative yearly mean calorific value  $\overline{H}_x(y)$  is calculated from monthly volumes  $V(m)$  and monthly calorific values  $\overline{H}_x(m)$  or  $H'_x(m)$ :

$$\overline{H_x(y)} = \frac{\sum_1^{m=12} \overline{H_x(m)} V(m)}{\sum_1^{m=12} V(m)} \quad (3)$$

In charging areas where  $j$  gases of different calorific values are fed into the area at the same input point and mixed, the representative calorific value  $\overline{H}$  is determined by measuring the calorific value of the mixture or by calculating the mean calorific value as the volume weighted mean value from the volumes and calorific values of the  $j$  individual gas streams:

$$\overline{H} = \overline{H_x} \quad (4)$$

or

$$\overline{H} = \frac{\sum_1^j H_j V_j}{\sum_1^j V_j} \quad (4')$$

In charging areas where gases of different calorific values are fed into the area at locally different input points, the calorific values are determined for each input point ( $H_x$ ). If the calorific values at the different input points do not differ by more than the maximum permissible error in use from the volume weighted mean value for this charging area, this volume weighted mean value can be used. Otherwise, a more or less sophisticated state reconstruction system (which itself is subject to approval) shall be used.

$$\left( \overline{H_x} - \overline{H} \right)_{\text{for all } x} \leq \text{mpe}_{\text{in service}} \Rightarrow \overline{H} = \overline{H_x} \quad (5)$$

$$\left( \overline{H_x} - \overline{H} \right)_{\text{for any } x} > \text{mpe}_{\text{in service}} \Rightarrow \text{State reconstruction} \quad (5')$$

## Annex D

### General considerations on gas measuring systems

(Informative)

#### D.1 Constituting of an energy measuring system

Below are the different possibilities for making a legal measuring system starting from a volume indication converted at base conditions. It has to be adapted in case of a converted mass or a direct mass.

In principle, communications concerning the metering module are secured.

For conversion functions either any communication shall be secured or the communications between the VCD and the ECD and between the CVDD and the ECD shall be such that a documented provisions system ensures that appropriate data are used as described hereafter. The principle of a documented provisions system is also applicable when the pressure is not measured at the metering point.

#### ABBREVIATIONS AND SYMBOLS

M	Meter
VMC	Volume at metering conditions
VCD	Volume conversion device
VBC	Volume at base conditions
CVDD	Calorific value determining device
ECD	Energy conversion device
E	Energy
SL —	Secured communication
NS ---	Non secured communication
ME →	Manually entered data

#### FIRST CASE

Secured communications and a CVDD close to the meter

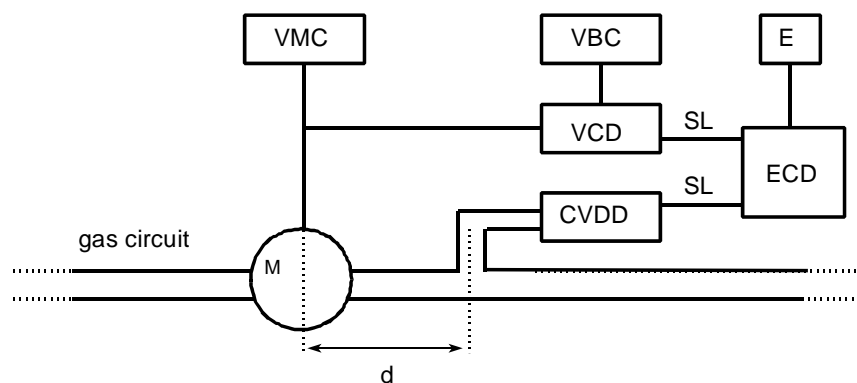

This system is a classical legal measuring instrument.

*Note:* The distance  $d$  is so that the characteristics of the metered gas are the same as those of the gas which is analyzed in the CVDD.



**SECOND CASE****Secured communications and a remote CVDD**

This is the case for instance where only one CVDD is used to determine the calorific value for a region.

*Note:* The distance between the ECD and the remaining parts of the measuring system is not relevant, neither is the number of ECDs.

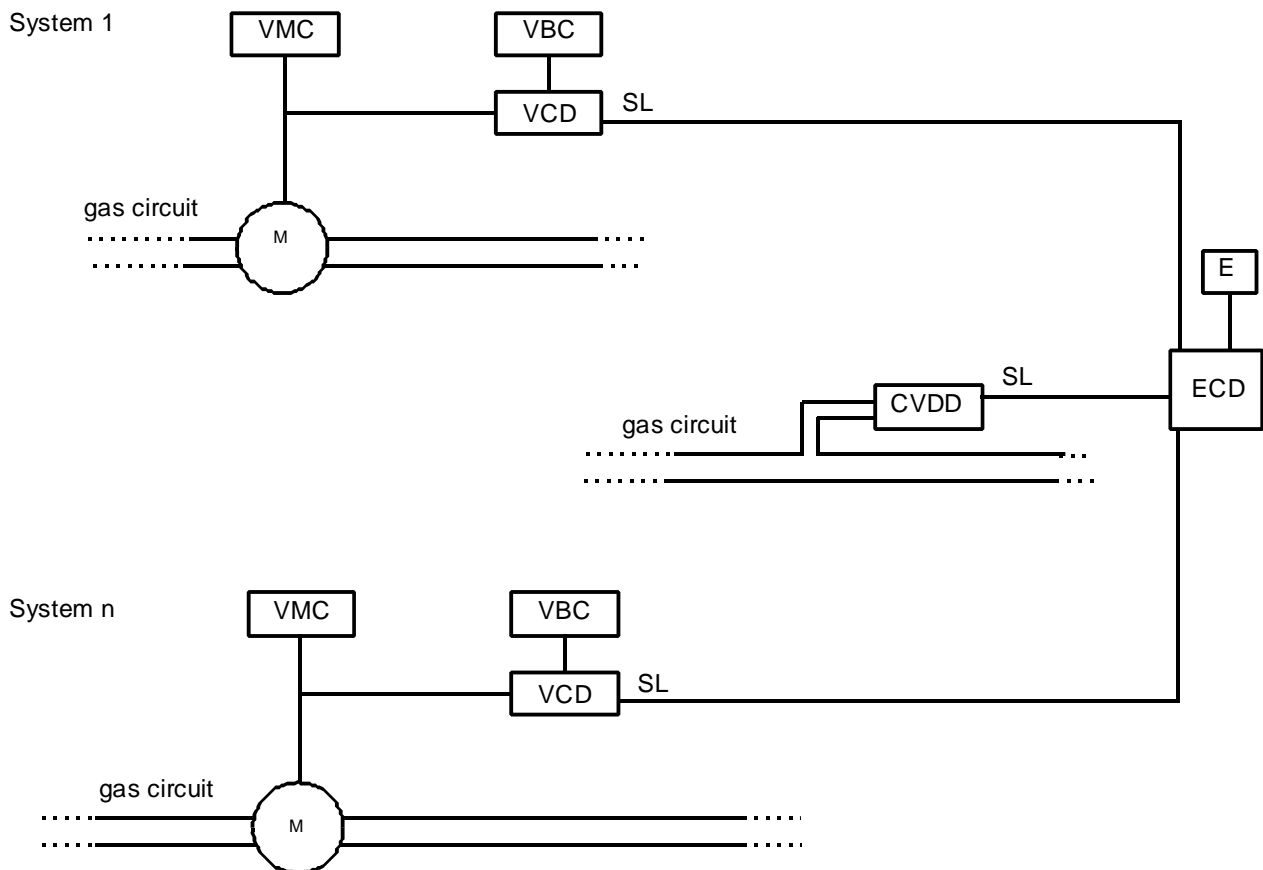

A legal measuring instrument is made up of:

- a measuring system itself; and
- documented provisions ensuring that data used for computing the energy are representative of the calorific value of the gas passing through each meter.

*Note:* Documented provisions are left to national authorities.

**THIRD CASE**

Non secured communications and/or manually entered data

*Note:* This is the relevant case where at least one communication is not secured.

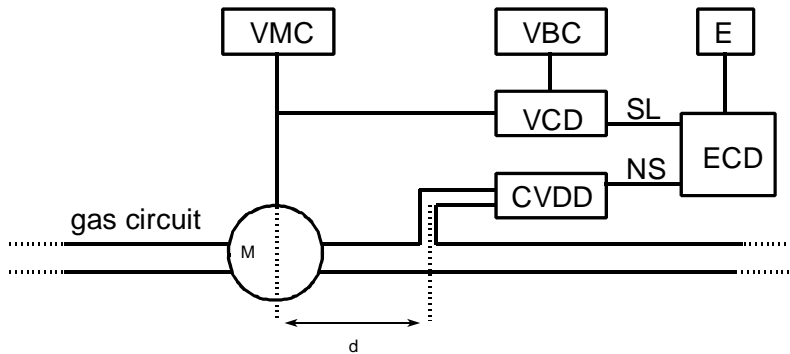
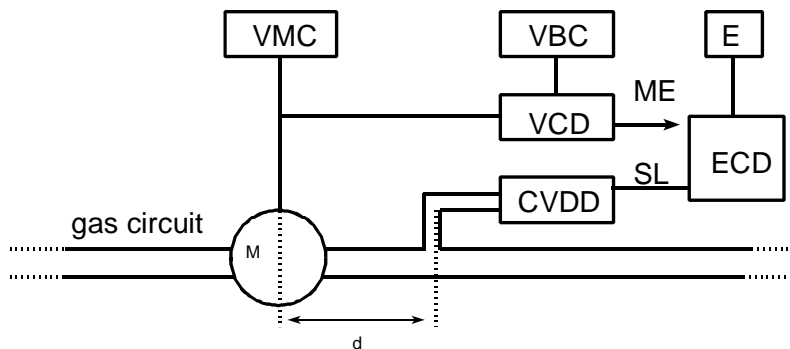
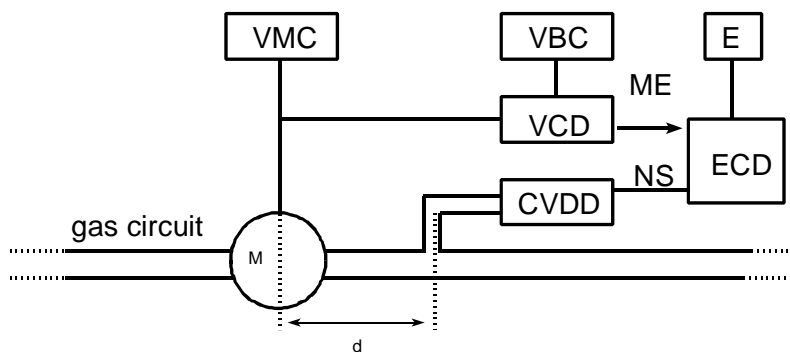
First exampleSecond exampleThird example

A legal measuring instrument is made up of:

- a measuring system itself; and
- documented provisions ensuring that data used for computing the energy are correct, i.e. they are those measured by the VCD and the CVDD; and
- moreover in the case of a remote CVDD, documented provisions ensuring that data used for computing the energy are representative of the calorific value of the gas passing through each meter.

*Note:* Documented provisions are left to national authorities.

## **D.2 Flow measurement technologies**

Meters fitted in measuring systems in the scope of this Recommendation may be of any technology with the exception of diaphragm meters, although the complete modular approach is only possible for technologies considered in Annex B.

### **D.2.1 Orifice plate, venturi, nozzle gas meters**

See ISO 5167 [40] [41].

### **D.2.2 Turbine meter**

A turbine meter is a meter in which the gas flow drives a wheel, the number of rotations of which corresponds to a measure proportional to the transmitted gas volume (see OIML R 137-1).

### **D.2.3 Rotary piston meter**

A rotary piston meter is a meter wherein the internal walls limiting measuring chambers are put into revolution under the action of gas; the number of revolutions of those walls corresponds to a measure for the transmitted gas volume (see OIML R 137-1).

### **D.2.4 Ultrasonic meter**

Meter determining the transmitted quantity of gas by integration of the gas flow, which is defined by the measure of the transit time needed by an ultrasonic wave (this time depends on the sound velocity in gas and the gas velocity) or by the Doppler frequency shift of an ultrasonic wave.

### **D.2.5 Vortex meter**

A vortex meter operates by sensing the vortices shed from alternative sides of a bluff body located in the flowing fluid. The frequency of vortex shedding is proportional to the Strouhal number of the fluid.

### **D.2.6 Coriolis mass flow instrument**

Measuring instrument that determines the mass of a quantity of flowing gas using the phenomenon of Coriolis strain without the use of any auxiliary device or data on the physical properties of the gas.

### **D.2.7 Other measurement principles**

Any other measurement principle giving an output signal in function of the volume, mass or energy having passed through the meter.

## **D.3 Design of measuring systems**

The design of a measuring system shall be based on the minimum and maximum values relating to:

- the volume, mass or energy flowrate;
- the design pressure and the operating pressure;
- the gas temperature and the ambient temperature; and
- the gas composition.

### **D.3.1 Minimal design criteria**

According to the above criteria, and additionally taking into account certain technical and economical considerations, the authorities may decide the constitution of measuring systems. The following table gives guidelines for this.

**Table 5 - Minimal design criteria for the constitution of measuring systems**

Design $Q_{\max}$ at base conditions. $\text{m}^3/\text{h}$	Less than or equal to 1 000	More than 1 000	More than 10 000	More than 100 000
Meter's curve error correction		*	*	*
Provision for local proving system			*	*
Temperature conversion	*	*	*	*
Pressure conversion		*	*	*
Z conversion		*	*	*
Local CV <sup>1</sup> and gas quality determination			* (or see row below)	*
Remote CV determination (sampling or computation)	*	*	*	
Registration of flow quantities per time intervals			*	*
Alternative for the above conversions: density measurement			*	*
Accuracy class	C	B	A or B	A

\* device or function advisable

<sup>1</sup> CV = calorific value

### D.3.2 Measurement of the characteristics of the gas

In order to achieve the best accuracy, the measurements of the characteristics of the gas (pressure, temperature, density) should be made on every measurement branch so that:

- it influences neither the flow nor the measurement of the transmitted quantity; and
- it ensures the values of the measured quantities corresponding to the conditions at the measuring point of the gas flow.

One associated measuring instrument is sufficient for the whole measuring system to measure parameters (density, calorific value, etc.) which are common to all the branches under normal operating conditions and to measure the gas composition, provided the maximum influence specified in 7.3.3.3 is respected.

For the density measurement, the use of two measuring instruments is recommended to detect an error in one of them.

### D.3.3 Optional equipment

The measuring system may transmit metrological information to other equipment such as totalizers, recorders or telemetry equipment. The legal status (subject to control or not) of transmitted information is subject to considerations of the authorities.

The variables measured at the metering station may be displayed, recorded or stored as analogical or digital data and may be recorded and stored by appropriate devices as a function of time and volume.

### **D.3.4 Ambient temperature**

Some types of equipment, such as calculators and other electronic devices, can only operate correctly within a limited temperature range (the rated operating conditions are specified in 7.1.2). Where controlled ambient temperature is required to maintain the accuracy of this type of equipment, the operator should verify that the ambient temperature is properly monitored and maintained.

## **D.4 Provisions concerning the inlet flow profile**

For all types of meter technologies affected by the inlet flow it is essential to have fully developed gas flow profiles, pertinent to the fluid and flow conditions.

### **D.4.1 Conditions**

Vortex conditions and velocity profiles may be accepted if the effect is smaller than specified by the meter's manufacturer or if it is within the appropriate product standard.

### **D.4.2 Piping requirements**

In order to reach acceptable flow profile conditions, the general measures below will be taken. These measures can be connected with the specific remarks relating to different types of meters and stated in D.2 taking into account that all meters do not have the same sensitivity to flow profile disturbances. See D.4.4 for the assessment of other methods.

- a) The necessary upstream and downstream piping as well as the gas meter should all have the same nominal bore.
- b) Any valve at the inlet of the straight pipework upstream of the meter should normally be a full bore valve having the same diameter as the pipe. This valve should be fully open when the flow meter is making measurements.
- c) Additional precautions, regarding flow profile, should be taken if a flow regulating valve or a pressure regulator is located upstream of the meter.
- d) The use of pipe fittings or equipment generating markedly asymmetric or swirled flow profiles should be avoided over a sufficient length, depending on the meter type, upstream of the gas meter. For example single or double elbows, reducers, etc.
- e) Piping configurations that generate swirl. (For example bends that are not coplanar should be avoided over sufficient length - depending on the meter type - upstream of the gas meter, as swirling can persist over very long straight pipes lengths i.e. more than 100 D depending on the Reynolds number, pipe roughness, etc.).

### **D.4.3 Flow conditioners**

If the conditions required upstream of a given meter to maintain its accuracy cannot be reached (for example because of insufficient space or because the measuring system is combined with a pressure regulating station), a flow conditioner should be required. The upstream distance in order to enable the flow profile to reach the quality required as far as the velocity profile and the turbulence distribution are concerned should be specified at the time of type approval.

As the flow conditioner influences the meter's accuracy, the meter and the flow conditioner should be calibrated as a single unit. The relative position of the meter and of the flow conditioner shall be secured.

### **D.4.4 Assessment of an acceptable flow profile**

When the piping and/or the flow conditioner do not provide the quality required for the upstream flow profile, there are two possibilities:

- a) either measure the flow profile and check whether the pipe flow profile at the meter's inlet is satisfactory according to the above described characteristics; or

b) calibrate the gas meter including its upstream piping and the flow conditioner if any, all being transported without disassembling after calibration or with special precautions to make sure that the pipework and meter are installed in the same position as during the calibration. (See preceding paragraph).

*Note:* This provision must be considered as an advice, for instance for gas industry, but must not be considered as contradicting Annex B.

#### **D.4.5 Unstable flow**

In some applications the gas flow may be pulsating, vibrating, intermittent or alternating. The resulting effects on the metering indication are dependent on the type of the meter, its design, the gas density and the working regime of the whole measuring system. This can lead to significant systematic measuring errors. The unstable flow effects should be taken into account at the design phase of the measuring system as well as at the time of selecting the meter.

##### **D.4.5.1 Pulsation effects**

Pulsation effects have to be checked when the meter is installed upstream or downstream of:

- piston-type compressors;
- rotary piston gas meters;
- dead end pipes generating resonances; or
- unstable pressure regulators.

The influence of pulsations can be reduced by increasing the distance between the meter and the pulsation source, or by using suitable pulsation dampers.

##### **D.4.5.2 Vibrations**

Vibrations can arise when the mechanical natural frequency of the pipe system is equal to or very close to the excitation frequency caused by elements as mentioned above (D.4.5.1), by the gas meters themselves or by flow induced pulsations. To prevent or minimize vibration effects on the gas meter appropriate calculations for the whole measuring system should be carried out, preferably at design stage. In particular, ultrasonic gas meters should not be installed where vibration frequencies (or their harmonics) might be close to the frequencies used by ultrasonic transducers.

##### **D.4.5.3 Intermittent flow**

An intermittent flow is generated if the flowrate repeatedly changes between a nearly constant flowrate to no flow. For gas meters with moving/rotating elements, in particular turbine gas meters, measuring errors of up to 20 % or more can be induced by “after-run” measurement. Furthermore, attention has to be paid to choose the optimum gas meter size. Oversized gas meters enlarge the after-run error. Intermittent flow errors can be avoided by selecting the appropriate type of meter and by avoiding oversized flow transducers.

##### **D.4.5.4 Alternating regime**

For alternating working regimes of a gas meter the statements about intermittent flows should be applied analogously.

#### **D.4.6 Specifications relating to rotary piston gas meters**

##### **D.4.6.1 Upstream velocity profile**

At low pressure, rotary displacement gas meters are generally not sensitive to the configuration of the piping. For higher pressures, for example above 700 kPa, it is necessary to place two straight sections of pipe upstream and downstream with the same nominal diameter as the meter’s flanges.

#### D.4.6.2 Pressure surges generated by the meter

Small volume variations during the operating cycle of the meter are inherent in the operation of some types of rotary displacement meters. These variations generate small pressure surges both upstream and downstream of the meter. Parallel or series configurations shall require adequate piping in order to eliminate the risk of interferences.

## Annex E

### Calibration gases

(Mandatory/informative)

#### E.1 Calibration gases for instruments for the determination of the calorific value

Calibration gases certified for calorific value and composition, where applicable, are used during type approval, initial verification, subsequent verification, and normal operation of calorific value measuring instruments, when authorized.

The general requirements concern the stability, preparation, certification and use. The specific (technical) requirements describe the fields of application and the properties (composition, certified values, purity, uncertainty).

According to the application the calibration gases imply different specific requirements.

<b>E.1.1</b> <b>General requirements</b>	<b>Possible method for fulfilling the requirement/Comments</b>
<b>E.1.1.1</b> Reactivity of gases	
The components of the calibration gas shall not react with each other.	Only saturated hydrocarbons, permanent gases and carbon dioxide shall be used.
<b>E.1.1.2</b> Reactivity with materials	
The gas components shall not react with or be influenced by materials used for the cylinder, valves, tubes, seals, etc.  Adsorption effects shall be avoided or minimized to a negligible extent.  Diffusion through sealings shall not occur.	cf. ISO 10715 [38] Ch. 6 – 7.



<b>E.1.1</b> <b>General requirements</b>	<b>Possible method for fulfilling the requirement/Comments</b>
<p><b>E.1.1.3</b>      Condensation</p> <p>During use, transport and storage no change of the quantitative and qualitative composition shall occur.</p> <p>During preparation, transport and storage, the temperature of the bottle shall not be reached or fall below the dew temperature, including a safety margin.</p> <p>During use, the temperature of the calibration gas cylinder shall exceed the dew temperature, including a safety margin.</p> <p>No retrograde condensation shall occur.</p> <p>During expansion through valves, tubes or pressure regulators, the cooling due to the Joule/Thomson effect shall not cause condensation.</p>	<p>The dew temperature of the gas shall be known and the gas maintained above that temperature.</p> <p>If necessary, a heating device shall be provided with the cylinder.</p> <p>If necessary, the respective devices shall be equipped with a heater of sufficient power to heat the gas far enough above ambient temperature, so that even with adiabatic expansion the temperature exceeds the dew temperature plus its safety margin.</p>

<b>E.1.1</b> <b>General requirements</b>	<b>Possible method for fulfilling the requirement/Comments</b>
	<p>The determination of the dew temperature and maximum pressures during and after the filling process has to be performed by:</p> <p>a) An appropriate measurement method (cf. ISO/TR 11150 [44]).</p> <p>b) Calculation with an appropriate computer program for phase properties.</p> <p>c) Estimation on the basis of calculated compression factors (cf. ISO 12213 [9] [10] [11]).</p> <p>d) Estimation on the basis of vapor pressures.</p> <p>These methods are given in the preferred order.</p>
<b>E.1.1.4</b> Life time and final pressure	
<p>The maximum lifetime of the calibration gases shall be specified.</p> <p>The final pressure in a calibration gas cylinder shall not fall below ambient pressure plus a safety margin sufficient to prevent diffusion of air into the cylinder.</p>	It should not exceed 5 years.
<b>E.1.1.5</b> Handling	
Calibration gases shall be handled according to the accepted good laboratory practice for pure gases by qualified personnel only.	
<b>E.1.1.6</b> Preparation, certification and traceability	
The preparation should preferably be done gravimetrically.	cf. ISO 6142 [42]
The final composition of the gas shall be checked by gas chromatography or any other appropriate method.	cf. ISO 6143 [43]
All calibration gases shall be traceable to national or international standards. The certification to the required uncertainties on calorific value or gas composition shall be performed by an authorized institution.	The calorific value can be calculated from the known composition, where the uncertainty of the concentration determinations is negligible regarding the mpes, or determined directly using a measuring instrument.

<b>E.1.1.7</b> Certificate	
Each cylinder shall be accompanied by a certificate and detailed instructions for the shipper.	The amount of information on this certificate is the mandatory and optional data as in ISO 6141 [34]. An extract of this information has to be affixed to the cylinder.  Especially, the minimum transport temperature shall be given.
<b>E.1.1.8</b> Units	
The unit of composition to be used is the mole or mass fraction; all other properties shall be given in the respective SI unit.	

## **E.1.2 Specific requirements for calibration gases for instruments for the determination of the calorific value**

### **E.1.2.1 Gases for type approval**

Calibration gases for type approval are chosen by the respective institution according to the property under investigation.

### **E.1.2.2 Gases for initial and subsequent verification**

Where appropriate, after each verification, the cylinders shall be sealed.

### **E.1.2.3 Gases for continuous adjustments and routine checks**

When authorized and according to the manufacturer's recommendation and the type approval results, none, one or more calibration gases of given certified (where applicable) composition and certified calorific value shall be used during the verification validity period for continuous calibration and adjustment (if applicable) of the instrument.

When only one calibration gas is used, it should have similar calorific values as the long-term mean value for the installation site. When two or more calibration gases are used, they should be equally spaced in order to cover the long-term CV-range for the installation site.

The calibration gas cylinders shall be permanently connected to the instrument, and the tubing shall be easily visible without additional connections. A technique preventing mixing of calibration gas and pipeline gas shall be used. All connections shall be sealed during verification.

The exchange of the calibration gas requires a new verification.

### **E.1.2.4 Gases for maintenance work**

If regular maintenance work during the verification validity period is necessary to keep the instrument in a properly functional condition, the calibration gases to be used are chosen during the type approval process according to the manufacturer's recommendation.

This maintenance work and the calibration shall be possible without breaking seals.

### E.1.3 Composition and physical properties

The calibration gas shall contain all the relevant components for the intended purpose, where necessary. Its physical and chemical properties (e. g. calorific value, density, Wobbe number) shall be suitable for the identification of the influencing factors by calibration and their elimination by adjustment.

#### E.1.3.1 Recommended mixtures

The following table summarizes the recommended compositions of the different categories of the calibration gas and the properties to be certified. Deviations from the recommendations may be specified in the type approval certificate.

Physical principle purpose	Direct measuring	Indirect measuring	Correlation techniques	Calculation from composition
Calibration	CH <sub>4</sub> H <sub>2</sub> CH <sub>4</sub> /N <sub>2</sub> CH <sub>4</sub> /C <sub>2</sub> H <sub>6</sub> CH <sub>4</sub> /N <sub>2</sub> /H <sub>2</sub>  certified for CV (H <sub>2</sub> ; CH <sub>4</sub> : purity)	according to physical principle as given by the type approval certificate certified for CV and the respective physical property		6 or more components*  certified for composition and CV
Verification	2 or 3 component mixtures as above certified for CV	6 or more component mixtures*  certified for CV		
Type approval	According to type approval bodies			
Maintenance	According to manufacturer's recommendation as specified in the type approval			

\* CH<sub>4</sub>, C<sub>2</sub>H<sub>6</sub>, C<sub>3</sub>H<sub>8</sub>, n-C<sub>4</sub>H<sub>10</sub>, N<sub>2</sub>, CO<sub>2</sub>

When preparing the mixtures, the relative deviation of the concentration of each component with respect to the nominal values given in the type approval in the final mixture shall be less than 5 % and the deviation of the calorific value less than 1 %.

#### E.1.3.2 Uncertainty of the certified values

For all calibration gases the uncertainty of the certified calorific value, as determined in ISO 6976 [12] § 9, shall be less than 1/3 of the maximum permissible error, as far as feasible.

Examples of uncertainties for calibration gases certified for composition:

- ethane, propane, 2-methylpropane, n-butane, nitrogen: 1 % relative;
- all other components: 2 % relative;
- methane: 0.2 % relative (if determined directly).

*Notes:*

- 1 If the composition of methane is not directly determined, this composition is the difference between 100 % and the sum of contents of other components.
- 2 Some National Authorities are used to comparing the difference between the directly measured calorific value (using a well known CVDD) and the calorific value calculated from the measured composition. In this case results shall be consistent taking into account uncertainties.

**E.1.3.3** Values used for calculation

The calculation of the properties of the gas shall be done according to ISO 6976 [12].

**Purity**

The recommended purity of the gases used for the mixtures and as pure gases is:

- nitrogen, carbon dioxide, hydrogen: 99.999 %
- methane: 99.995 %
- ethane, propane, n-butane: 99.95 %
- all other components: 99 %

Lower purity gases are allowed subject to the impurities being certified and their concentrations taken into account in calculating the mixture composition and calorific value.

The determination of the purity shall be performed by an authorized institution.

**Examples for mixtures**

## a) Calibration gases for calorimeters

Component										
Nitrogen	$\text{N}_2$					7.00	8.70	11.70	17.5	17.00
Hydrogen	$\text{H}_2$		99.9990							49.00
Methane	$\text{CH}_4$	99.995		87.70	93.50	93.00	91.30	88.30	82.50	34.00
Ethane	$\text{C}_2\text{H}_6$			12.30	6.50					
<b>Calorific value</b>	<b>MJ/m<sup>3</sup></b>	39.831	12.752	43.545	41.793	37.036	36.358	35.160	32.846	19.769
<b>Standard density</b>	<b>kg/m<sup>3</sup></b>	0.7175	0.0899	0.7952	0.7585	0.7548	0.7639	0.7799	0.8108	0.5001

## b) Calibration gases for gas chromatographs

Component										
Helium	$\text{He}$									0.50
Oxygen	$\text{O}_2$							0.50		0.50
Nitrogen	$\text{N}_2$	0.40	14.40	12.00	10.30	1.00	4.00	4.00	4.00	5.00
Carbon dioxide	$\text{CO}_2$	1.80	1.00	4.50	1.00	0.9	1.50	1.50	1.50	1.00
Carbon monoxide	$\text{CO}$									0.50
Hydrogen	$\text{H}_2$									1.00
Methane	$\text{CH}_4$	84.00	81.00	82.00	83.00	96.40	83.85	88.45	88.90	86.44
Ethene	$\text{C}_2\text{H}_4$									0.50
Ethane	$\text{C}_2\text{H}_6$	9.40	3.00	0.75	4.00	1.00	8.20	4.00	4.00	2.50
Propene	$\text{C}_3\text{H}_6$									0.50
Propane	$\text{C}_3\text{H}_8$	3.40	0.50	0.30	1.25	0.25	2.00	1.00	1.00	1.00
n-Butane	$\text{C}_4\text{H}_{10}$	1.00	0.10	0.20	0.20	0.20	0.20	0.20	0.20	0.20
2-Methylpropane (iso-Butane)	$\text{C}_4\text{H}_{10}$			0.20	0.20	0.20	0.20	0.20	0.20	0.20
n-Pentane	$\text{C}_5\text{H}_{12}$							0.05	0.05	0.05
2-Methylbutane (iso-Pentane)	$\text{C}_5\text{H}_{12}$			0.05	0.05	0.05	0.05	0.05	0.05	0.05
2,2-Dimethylpropane (Neopentane)	$\text{C}_5\text{H}_{12}$								0.05	
n-Hexane	$\text{C}_6\text{H}_{14}$							0.05	0.05	0.06
<b>Calorific value</b>	<b>MJ/m<sup>3</sup></b>	44.729	34.977	37.074	37.691	39.942	41.727	39.794	40.053	38.926
<b>Standard density</b>	<b>kg/m<sup>3</sup></b>	0.8635	0.8339	0.8552	0.8348	0.7524	0.8435	0.8107	0.8084	0.8028

## Annex F

### Minimum test quantities for measuring systems and devices

#### (Informative)

Provided that it can be assumed that the largest uncertainty component is due to the rounding of the digital scale intervals, the following may be considered.

In the case of a digital scale interval  $s$  and the determination of the errors of a meter it can be demonstrated that the distribution law is triangular and that the standard uncertainty  $u_s$  is:

$$u_s = \frac{s}{\sqrt{6}}$$

For this, it has to be considered that a single reading provides a rectangular distribution and that the reading of a metered quantity is made by taking the difference between 2 consecutive values, which results in a triangular distribution.

With a coverage factor equal to 2, the expanded corresponding uncertainty  $U$  is:

$$U = 2 u_s$$

The requirement on uncertainty at type approval comparing to the tolerance  $T$  is:

$$U \leq \frac{T}{3}$$

That is:

$$s \times \sqrt{6} \leq T$$

1) Case of determining the error of a complete measuring system with mpe = ± 1.5 % (example)

$$T = \text{mpe} = 1.5 \times 10^{-2} \times Q$$

The quantity  $Q$  is:

$$Q = n \times s$$

Where  $n$  is the number of scale intervals, which is in fact what we are looking for. This leads to:

$$s \times \sqrt{6} \leq 0.015 \times n \times s$$

That is:

$$n \geq \frac{100\sqrt{6}}{1.5} = 163.3$$

Rounded to:

$$n \geq 164$$

2) Case of determining the error of a metering module with  $mpe = \pm 1 \%$  (possible example at initial verification; see B.6)

$$n \geq 163.3 \times 1.5/1$$

$$n \geq 245$$

3) Case of determining the repeatability of a meter with a tolerance =  $\pm 0.3 \%$  (example)

$$n \geq 163.3 \times 1.5/0.3$$

$$n \geq 817$$

4) Case of determining the error of a class A calculator

$$T = 5 \times 10^{-4} \times n \times s$$

$$n \geq 163.3 \times 1.5 \times 10^{-2} / 5 \times 10^{-4}$$

$$n \geq 4\,899$$

5) Case of determining the fault of a class A calculator measuring volume at metering conditions

$T = SF$  (significant fault)

$$T = mpe / 10 = 0.7 \times 10^{-3} \times n \times s$$

$$n \geq 3\,500$$

## Conclusion

For measuring systems or metering modules it is necessary to calculate the minimum test quantity for each application. The number of scale intervals which is found should be increased because the assumption "it can be assumed that the largest uncertainty component is due to the rounding of the digital scale intervals" is not true in general.

For calculators, the above cases 4 and 5 correspond to the most severe conditions and it is proposed to always perform tests on quantities corresponding to 5 000 scale intervals. However, when necessary (long tests), the appropriate number can be calculated.

*Note:* The assumption "it can be assumed that the largest uncertainty component is due to the rounding of the digital scale intervals" is true in general for calculators.



## Annex G

### Conversion of gas mass to volume at base conditions

#### (Informative)

##### G.1 Calculation of volume at base conditions from mass

Knowing the weight or mass ( $w$ ) of a quantity of gas, the equation to calculate volume at base conditions ( $V_b$ ) is as follows:

$$V_b = \frac{w}{\rho_b} \quad \text{Eq. (1)}$$

Where:

$w$  = Weight or mass of gas

$V_b$  = Volume of gas at base conditions

$\rho_b$  = Density of gas at base conditions

##### G.1.1 Calculation of volume flowrate at base conditions from mass flowrate

Knowing the weight or mass flowrate ( $Q_m$ ) of a quantity of gas, the equation to calculate volume at base conditions flowrate ( $Q_{v_b}$ ) is as follows:

$$Q_{v_b} = \frac{Q_m}{\rho_b} \quad \text{Eq. (1.1)}$$

Where:

$Q_m$  = Weight or mass flowrate of gas

$Q_{v_b}$  = Volume flowrate of gas at base conditions

$\rho_b$  = Density of gas at base conditions

**G.1.2 Typical units of measure for volume at base condition calculations**

Variable	SI Units
$w$	kg
$V_b$	$m^3$
$Q_m$	kg/h
$Q_{v_b}$	$m^3/h$
$\rho_b$	$kg/m^3$

**G.2 Calculation of density at base conditions using non-ideal gas law**

The calculation of gas density at base conditions ( $\rho_b$ ) is dictated by the non-ideal gas law. The equation is as follows:

$$\rho_b = \frac{P_b M_r}{Z_b R T_b} \quad \text{Eq. (2)}$$

Where:

- $\rho_b$  = Density of gas at base conditions
- $P_b$  = Pressure of the gas at base conditions
- $M_r$  = Molar mass of the gas
- $Z_b$  = Compressibility of the gas at base conditions
- $R$  = Universal gas constant
- $T_b$  = Temperature at base conditions

### G.2.1 Calculation of base density using relative density

An alternate method to calculate the density of the gas at base conditions ( $\rho_b$ ) is by utilizing the relative density ( $G_r$ ) or specific gravity of the gas. This equation is as follows:

$$\rho_b = G_r \rho_{b(Air)} \quad \text{Eq. (2.1)}$$

Where:

$\rho_b$  = Density of gas at base conditions

$G_r$  = Relative density of the gas at base conditions

$\rho_{b(Air)}$  = Density of air at base conditions

### G.2.2 Typical units of measure for base density calculations

Variable	SI Units
$\rho_b$	kg/m <sup>3</sup>
$P_b$	MPa
$M_r$	kg/mol
$Z_b$	dimensionless
$R$	MPa.m <sup>3</sup> /mol.K (0.00831451)
$T_b$	K
$G_r$	dimensionless
$\rho_{b(Air)}$	kg/m <sup>3</sup> (1.2254 kg/m <sup>3</sup> at 0.101325 MPa and 288.15 K) (1.2254 kg/m <sup>3</sup> at 101.325 kPa and 15 °C)

### G.3 Calculation variables in section 2.0 for the determination of density at base condition ( $\rho_b$ )

#### G.3.1 Pressure at base condition ( $P_b$ )

The pressure at base conditions is determined by contractual agreements, common units and conversions are as follows.

Unit A	Conversion (Unit A $\times$ Conversion = Unit B)	Unit B
bar	100 000	Pa
kPa	1 000	Pa
MPa	1 000 000	Pa

#### G.3.2 Molar weight ( $M_r$ )

Molar weight of a gas ( $M_r$ ) in “kg/mol” is calculated in accordance with the following equation:

$$M_r = \sum_{i=1}^N x_i M_{ri}$$

Where:

$M_{r(gas)}$  = Molar weight of the gas

$N$  = Number of components in the gas mixture

$i$  = Component number sequence,  $i$  through  $N$

$x_i$  = Mole fraction component number  $i$

$M_{ri}$  = Molar weight of component  $i$

As an example, the molar weight of a three component mixture of natural gas containing 90 % methane, 5 % carbon dioxide, and 5 % nitrogen would be calculated as follows.

Natural gas component	Molar weight kg/mol		Molar fraction (%)		Product molar weight and fraction
Methane	16.043	×	0.900	=	14.439
N <sub>2</sub>	28.013	×	0.050	=	1.401
CO <sub>2</sub>	44.010	×	0.050	=	2.201
Ethane	30.170	×	0.000	=	0.000
Propane	44.097	×	0.000	=	0.000
I-Butane	58.123	×	0.000	=	0.000
N-Butane	58.123	×	0.000	=	0.000
I-Pentane	72.150	×	0.000	=	0.000
N-Pentane	72.150	×	0.000	=	0.000
N-Hexane	86.177	×	0.000	=	0.000
N-Heptane	100.204	×	0.000	=	0.000
N-Octane	114.231	×	0.000	=	0.000
N-Nonane	128.258	×	0.000	=	0.000
$M_{r(gas)} = (\text{Sum of products})$					18.040

### G.3.3 Compressibility factor at base conditions ( $Z_b$ )

The calculation of base compressibility can either be accomplished by the method according to ISO 6976 [12], or by other methods recognized by National Authorities (for use at the national level only).

## Annex H

### Bibliography

#### (Informative)

- [1] OIML V 2-200 International Vocabulary of Metrology - Basic and General Concepts and Associated Terms (VIM). OIML, Paris, 2007
- [2] International vocabulary of terms in legal metrology (VIML). OIML, Paris, 2000
- [3] Bureau International des Poids et Mesures (1998): The International System of Units (SI), Organisation Intergouvernementale de la Convention du Mètre, 7th edition, BIPM, Paris, 1998
- [4] Bureau International des Poids et Mesures (2000): The International System of Units, Supplement 2000: addenda and corrigenda to the 7th edition (1998), BIPM, Paris, 2000
- [5] OIML International Document D 2: Legal units of measurement, OIML, Paris, 1999
- [6] OIML International Document D 11: General requirements for electronic measuring instruments. OIML, Paris, 2004
- [7] Guide to the expression of uncertainty in measurement. BIPM, IEC, IFCC, ISO, IUPAC, IUPAP and OIML. International Organization for Standardization, Geneva, 1995
- [8] OIML Recommendation R 137-1: Gas meters – Part 1: Requirements, OIML, Paris, 2006
- [9] ISO 12213-1 (2006): Natural gas — Calculation of compression factor — Part 1: Introduction and guidelines, ISO, Geneva, 2006
- [10] ISO 12213-2 (2006): Natural gas — Calculation of compression factor — Part 2: Calculation using molar-composition analysis, ISO, Geneva, 2006
- [11] ISO 12213-3 (2006): Natural gas — Calculation of compression factor — Part 3: Calculation using physical properties, ISO, Geneva, 2006
- [12] ISO 6976 (1995) with corrigendum 1 (1997), corrigendum 2 (1997) and corrigendum 3 (1999): Natural gas, calculation of calorific values, density, relative density, Wobbe index from composition, ISO, Geneva, 1995.
- [13] IEC 60068-2-4 (2007-03) Environment testing Part 2-1: Tests – Test A: Cold
- [14] IEC 60068-2-2 (2007-07) Environmental testing - Part 2-2: Tests - Test B: Dry heat
- [15] IEC 60068-3-1 (1974-01) with amendment 1 (1978-01) Environmental testing - Part 3: Background information - Section One: Cold and dry heat tests
- [16] IEC 60068-3-4 (2001-08) Environmental testing Part 3-4: Supporting documentation and guidance - Damp heat tests
- [17] IEC 60068-2-30 (2005-08) Environmental testing Part 2: Tests. Test Db and guidance: Damp heat, cyclic (12 + 12-hour cycle)
- [18] IEC 60068-2-31 (2008-05) Environmental testing - Part 2-31: Tests - Test Ec: Rough handling shocks, primarily for equipment-type specimens
- [19] IEC 60068-2-47 (2005-04) Environmental testing Part 2-47: Test methods, Mounting of components, equipment and other articles for vibration, impact and similar dynamic tests
- [20] IEC 60068-2-64 (2008-04) Environmental testing - Part 2-64: Tests - Test Fh: Vibration, broadband random and guidance
- [21] IEC 60068-2-78 (2001-08) Environmental testing - Part 2-78: Tests - Test Cab: Damp heat, steady state

- [22] IEC 60654-2 (1979-01) with amendment 1 (1992-09) Operating conditions for industrial-process measurement and control equipment. Part 2: Power
- [23] IEC 61000-2-2 (2002-03) Electromagnetic compatibility (EMC) - Part 2-2: Environment - Compatibility levels for low-frequency conducted disturbances and signalling in public low-voltage power supply systems
- [24] IEC 61000-4-1 (2006-10) Electromagnetic compatibility (EMC) - Part 4-1: Testing and measurement techniques - Overview of IEC 61000-4 series
- [25] IEC 61000-4-2 (2001-04) Electromagnetic compatibility (EMC)- Part 4-2: Testing and measurement techniques - Electrostatic discharge immunity test
- [26] IEC 61000-4-3 (2008-04) Electromagnetic compatibility (EMC) - Part 4-3: Testing and measurement techniques - Radiated, radio-frequency, electromagnetic field immunity test
- [27] IEC 61000-4-4 (2004-07) Electromagnetic compatibility (EMC) - Part 4-4: Testing and measurement techniques - Electrical fast transient/burst immunity test
- [28] IEC 61000-4-5 (2005-11) Electromagnetic compatibility (EMC)- Part 4-5: Testing and measurement techniques - Surge immunity test
- [29] IEC 61000-4-6 (2006-05) Electromagnetic compatibility (EMC) - Part 4-6: Testing and measurement techniques - Immunity to conducted disturbances, induced by radio-frequency fields
- [30] IEC 61000-4-11 (2004-03) Electromagnetic compatibility (EMC)- Part 4-11: Testing and measuring techniques - Voltage dips, short interruptions and voltage variations immunity tests
- [31] IEC 61000-6-1 (2005-03) Electromagnetic compatibility (EMC) - Part 6-1: Generic standards - Immunity for residential, commercial and light-industrial environments
- [32] IEC 61000-6-2 (2005-01) Electromagnetic compatibility (EMC) - Part 6-2: Generic standards - Immunity for industrial environments
- [33] IEC 60751 (1983-01) with amendment 1 (1986-01) and amendment 2 (1995-07) Industrial platinum resistance thermometer sensors
- [34] ISO 6141 (2000) Gas analysis — Requirements for certificates for calibration gases and gas mixtures
- [35] ISO/TR 7066-1 (1997) Assessment of uncertainty in calibration and use of flow measurement devices — Part 1: Linear calibration relationships
- [36] ISO 7066-2 (1988) Assessment of uncertainty in the calibration and use of flow measurement devices — Part 2: Non-linear calibration relationships
- [37] ISO 6551 (1982) Petroleum liquids and gases — Fidelity and security of dynamic measurement -- Cabled transmission of electric and/or electronic pulsed data
- [38] ISO 10715 (1997) Natural gas — Sampling guidelines
- [39] IEC/TR 61000-2-1 (1990-05) Electromagnetic compatibility (EMC) Part 2: Environment Section 1: Description of the environment — Electromagnetic environment for low-frequency conducted disturbances and signalling in public power supply systems
- [40] ISO 5167-1 (2003) Measurement of fluid flow by means of pressure differential devices inserted in circular cross-section conduits running full — Part 1: General principles and requirements
- [41] ISO 5167-2 (2003) Measurement of fluid flow by means of pressure differential devices inserted in circular cross-section conduits running full — Part 2: Orifice plates
- [42] ISO 6142 (2001) Gas analysis — Preparation of calibration gas mixtures — Gravimetric method
- [43] ISO 6143 (2001) Gas analysis — Comparison methods for determining and checking the composition of calibration gas mixtures
- [44] ISO/TR 11150 (2007) Natural gas - Hydrocarbon dew point and hydrocarbon content